

# OWNER'S MANUAL 2009

**85 SX, XC**  
**105 SX, XC**

3211346en



**KTM**

Now you own a modern motorcycle that you and your youngster will certainly enjoy, provided that you service and maintain it properly.

Please insert the serial numbers of the motorcycle below

Chassis number

Engine number

Stamp of dealer

All information contained is without obligation. KTM-Sportmotorcycle AG particularly reserves the right to modify any equipment, technical specifications, prices, colors, shapes, materials, services, service work, constructions, equipment and the like so as to adapt them to local conditions or to cancel any of the above items, all without previous announcement and without giving reasons. KTM may stop manufacturing certain models without previous notice. KTM shall not be held liable for any deviations of availability and/or ability to deliver, illustrations, descriptions, printing and/or other errors. The illustrated models partly contain extra equipment, which is not applied to standard models.

© 2008 by KTM-SPORTMOTORCYCLE AG, Mattighofen AUSTRIA; All rights reserved; Reprint, also in extracts, with written allowance of KTM-SPORTMOTORCYCLE AG, Mattighofen only.



In accordance with the international quality management ISO 9001 standard, KTM uses quality assurance processes that lead to the highest possible product quality.

## INTENDED PURPOSE

KTM mini-sports motorcycles are designed and constructed to resist the usual wear and tear of normal use in competitions.

The motorcycles comply with the regulations and categories currently in effect with the leading international motorcycle associations.

## OWNER'S MANUAL

Please read this manual thoroughly before letting your youngster ride the motorcycle for the first time. This manual contains important information and recommendations that will help you and your youngster to operate and handle the motorcycle properly. In the interest of everybody involved, we urge you to pay particular attention to instructions and information marked as follows:

### **WARNING**

- Ignoring these instructions can be dangerous to life and limb!

### **CAUTION**

- Ignoring these instructions may damage parts of the motorcycle or impair the motorcycle's traffic safety!

This manual contains important information on the operation and maintenance of your new KTM motorcycle. It went to press describing your model's latest state of development. Nevertheless, the descriptions may deviate slightly from the current design as our motorcycles are permanently improved. The Owner's Manual is an integral part of the motorcycle and must be handed over to the new owner when the motorcycle is sold.

## SERVICE

Observance of the service, maintenance and tuning instructions for the engine and chassis specified in the Owner's Manual is a prerequisite for faultless operation and the avoidance of premature wear. An improperly tuned chassis can lead to damage and breakage of the chassis components (see chapter on checking the basic chassis setting).

The use of the motorcycle under extreme conditions, e.g. on extremely muddy and wet terrain, can lead to higher than average wear on components such as the drive train or the brakes. In this case it may become necessary to service or replace wear parts before the service limit specified in the maintenance schedule has been reached.

We expressly point out that work marked with an asterisk (\*) in the chapter "Maintenance work on the chassis and engine" must be performed by a KTM workshop. If maintenance work should become necessary during a competition, it must be performed by a trained mechanic.

Please strictly observe the prescribed running-in periods and inspection and maintenance intervals. Compliance with these instructions will significantly prolong the life of your motorcycle.

## **WARRANTY**

The service work specified in the "Lubrication and Maintenance Schedule" must be performed by a KTM workshop and recorded in the service manual otherwise claims under the warranty shall become void. No claims can be filed under the warranty for damage or consequential damage caused by manipulations or conversions to the motorcycle.

## **AUTOMOTIVE FLUIDS**

The fuels and lubricants specified in the Owner's Manual or automotive fluids with equivalent specifications must be used in accordance with the maintenance schedule.

## **SPARE PARTS, ACCESSORIES**

For the safety of your child, only use spare parts and accessories approved by KTM. KTM shall not assume any liability for other products or consequential damage resulting from the use of such products. When special needs arise, please contact a KTM dealer, who will seek the assistance of the KTM importer if necessary.

## **SAFETY**

Parents should keep in mind that the safety of their youngsters always depends on the efforts made by the parents to ensure that the motorcycle is kept in good working order and only used on safe terrains. Nevertheless, driving the motorcycle, like driving any other vehicle, involves a potential risk. Therefore, please make sure that all fundamental precautions are taken. Please also read the „INFORMATION ON SAFE DRIVING FOR PARENTS“ on page 4.

## **TRANSPORT**

When transporting your motorcycle, secure it with elastic straps or other mechanical devices in an upright position. Be sure that the fuel tap is closed. If the motorcycle topples over, fuel can flow out of the carburetor or fuel tank.

## **ENVIRONMENT**

Riding an off-highway motorcycle is a wonderful form of outdoor recreation and we certainly hope that you and your youngsters will enjoy it to the full. However, this enjoyable outdoor activity can cause environmental problems or lead to conflicts with other people. Responsible use of the motorcycle will prevent such problems and conflicts. You can contribute to securing the future of motorcycling by making sure that you and your youngsters only use the motorcycle within the limits established by the applicable laws, making environmental protection one of your top priorities and never violating other people's rights.

In this spirit, we hope that you and your youngsters will always safely enjoy your motorcycle!

KTM-SPORTMOTORCYCLE AG  
5230 MATTIGHOFEN, AUSTRIA

Attachments: 1 spare parts manual chassis & engine



**The 85/105 SX/XC mini motorcycles are off-road motorcycles designed for one person only. They are not allowed on public roads.**

The vehicle dimensions and components are designed for children from 10 to 15 years of age with a maximum weight of 75 kg (33,98 lb).

- Have your youngster wear proper protective gear whenever he or she rides the motorcycle: helmet, eye protection, chest, back, arm and leg protectors, gloves and boots. To set a good example, be sure to wear protective gear yourself whenever riding a motorcycle!
- Before your youngster takes his or her first ride, explain how each of the controls works and check if your youngster has understood what you explained. We recommend to review the entire owner's manual with your youngster item by item, paying particular attention to the specially marked warnings and pointing out the danger of injury.
- Instruct your youngster about riding and falling techniques, explain how the motorcycle will respond to shifting of the rider's weight, etc.
- Before starting the motorcycle for the first time check whether the basic fork and shock absorber settings are suitable for your child's weight (see chapter on checking the basic chassis setting)
- Before using the motorcycle you should always check all components for proper operation (see maintenance schedule). Have your youngster perform these technical checks himself / herself as well.
- Whenever you go for a ride with your youngster, keep in mind that the speed should be adjusted to your youngster and not the other way around.
- Your youngster must understand that all instructions he or she receives from you or any other supervising adult must be followed.
- Your child must be physically ready to ride a motorcycle. This means that he or she must at least be able to ride a bicycle. Being good at sports that require fast reactions is an additional advantage. Your youngster should be strong enough to pick up the motorcycle after a fall.
- Never demand too much of your youngster. Give him or her time to get used to the motorcycle and to improve his / her riding skills. Do not even consider letting your youngster participate in a race before his / her physical condition, riding skills and motivation have sufficiently developed.
- Explain to your youngster that he / she should always adjust his / her riding speed to the local conditions as well as to his / her own riding skills and that excessive speed can cause falls and severe injuries. Always keep in mind that youngsters tend to underestimate dangers or fail to recognize them altogether. The riding speed must be reduced, in particular, on unknown terrain.
- Never let your youngster ride the motorcycle without supervision. An adult should always be present.
- The motorcycle is designed for one rider only. Your youngster is not allowed to transport a passenger.
- When you go for a ride, somebody at home should always know where you are going and when you will be back. This makes it easier to send you help, should problems occur.

# TABLE OF CONTENTS »

	Page		Page
IMPORTANT INFORMATION FOR PARENTS ABOUT SAFE DRIVING .....	.4	Determining the static sag of the shock absorber . . . .	.18
SERIAL NUMBER LOCATIONS .....	.6	Determining the riding sag of the shock absorber . . . .	.18
Chassis number .....	.6	Overview of the shock absorber springs .....	.19
Engine number .....	.6	Checking the basic setup of the telescopic fork .....	.19
OPERATION INSTRUMENTS .....	.6	Overview of the telescopic fork springs .....	.19
Clutch lever .....	.6	Checking chain tension .....	.20
Hand brake lever .....	.6	Correct chain tension .....	.20
Short circuit button .....	.7	Chain maintenance .....	.20
Filler cap .....	.7	General information about KTM disc brakes .....	.21
Fuel tap .....	.7	Adjusting free travel of the hand brake lever .....	.21
Choke .....	.7	Checking the brake fluid level/ refilling .....	.22
Shift lever .....	.7	Checking front brake pads .....	.22
Kickstarter .....	.8	Replacing the front brake pads .....	.22
Foot brake pedal .....	.8	Changing basic position of the brake pedal .....	.23
Plugin- Stand .....	.8	Checking the rear brake fluid level .....	.23
Side stand .....	.8	Refilling the rear brake fluid reservoir .....	.23
Compression damping of fork .....	.8	Checking rear brake pads .....	.23
Rebound damping of fork .....	.8	Dismounting and mounting the front wheel .....	.24
Damping action during compression of shock absorber .	.9	Dismounting and mounting the rear wheel .....	.25
Rebound damping function of the shock absorber . . .	.9	Tires, air pressure .....	.25
GENERAL TIPS AND WARNINGS FOR STARTING THE MOTORCYCLE .....	.10	Checking spoke tension .....	.25
Instructions for the first ride .....	.10	Cleaning the air filter .....	.26
Running in .....	.10	Exhaust system .....	.26
DRIVING INSTRUCTIONS .....	.11	Changing the original position of the clutch lever . . .	.27
What you should check before each start .....	.11	Checking the oil level of the hydraulic clutch .....	.27
Starting when the engine is cold .....	.12	Bleeding of the hydraulic clutch .....	.27
Starting when the engine is warm .....	.12	Adjusting the throttle cable .....	.27
What to do when the engine is "flooded" .....	.12	Cooling system .....	.28
Starting off .....	.12	Checking coolant level .....	.28
Shifting/Riding .....	.12	Refilling/Bleeding the cooling system .....	.28
Refueling, fuel .....	.13	Carburetor adjustment .....	.29
Braking .....	.13	Draining the float chamber of the carburetor .....	.30
Stopping .....	.13	Checking gear oil level .....	.30
PERIODIC MAINTENANCE SCHEDULE .....	.14	Changing gear oil .....	.30
MAINTENANCE WORK ON CHASSIS AND ENGINE . . . .	.16	TRUBLE SHOOTING .....	.31
Checking and adjusting the steering head bearing . . .	.16	CLEANING .....	.33
Breather plug front fork .....	.16	STORAGE .....	.33
Cleaning the dust sleeves of the telescopic fork . . . .	.17	Use after period of storage .....	.33
How to change the handlebar position .....	.17	TECHNICAL SPECIFICATIONS – CHASSIS .....	.34
Changing the spring preloading of the shock absorber .	.17	TECHNICAL SPECIFICATIONS - ENGINE .....	.35
Basic suspension setup for the weight of the driver . .	.18	CARBURETOR SETTING .....	.37
Checking the shock absorber and spring .....	.18	HEAD WORD INDEX .....	.38

## SERIAL NUMBER LOCATIONS »

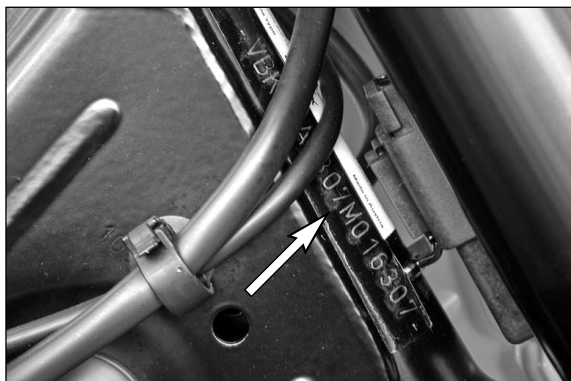

### Chassis number

The chassis number is stamped on the right side of the steering head tube. Enter this number in the field on page no 1.

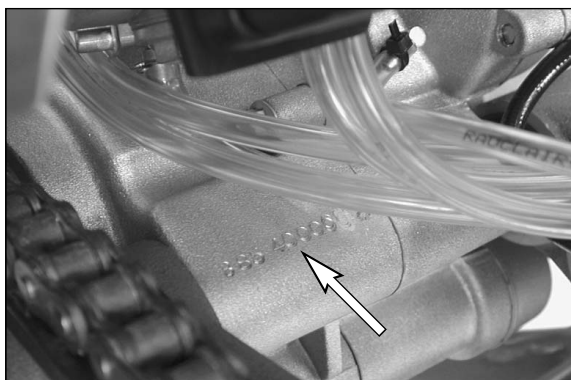

### Engine number

The engine number is stamped into the engine housing underneath the carburetor. Enter this number in the field on page no 1.

## OPERATION INSTRUMENTS »

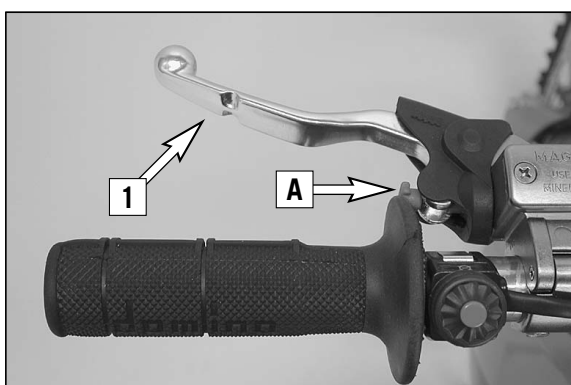

### Clutch lever

The clutch lever [1] is located on the left side of the handlebar. The adjusting screw [A] is used to change the original position of the clutch lever (see maintenance work on chassis and engine).

The clutch is hydraulically actuated and adjusts itself automatically.

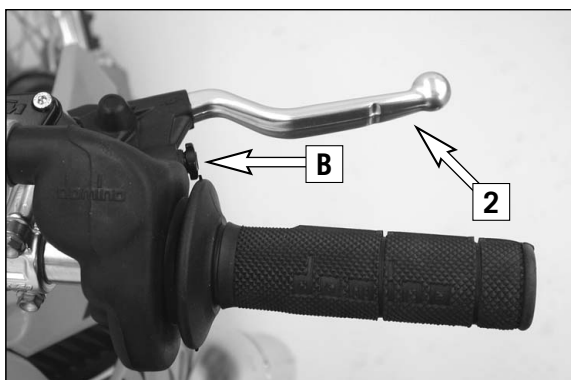

### Hand brake lever

The hand brake lever [2] is mounted on the handle bars on the right and actuates the front wheel brake. The adjusting screw [B] is used to change the original position of the hand brake lever (see maintenance work on chassis and engine).

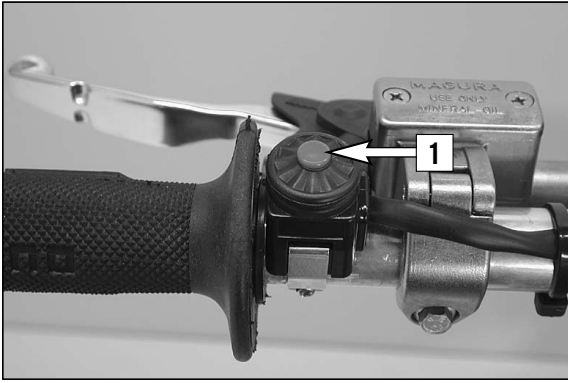

## Short circuit button

The short circuit button [1] turns off the engine. When pressing this button, the ignition circuit is short-circuited.

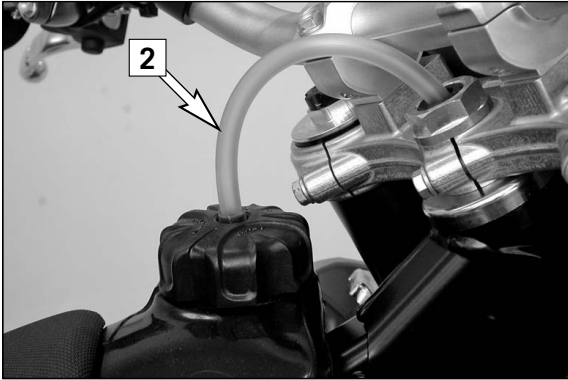

## Filler cap

**To open it:** turn filler cap counter-clockwise.

**To close it:** put filler cap back on and tighten it by turning it clockwise. Install tank breather hose [2] without kinks.

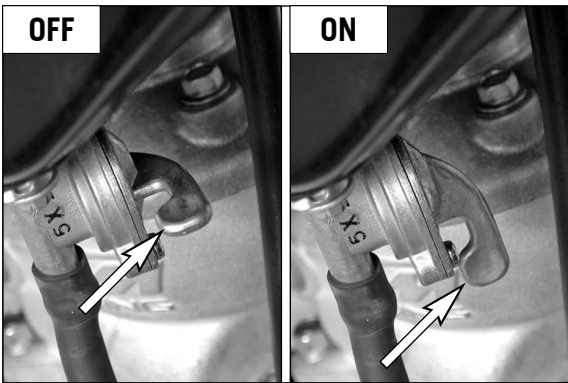

## Fuel tap

**OFF** In this position the fuel tap is closed. No fuel can flow to the carburetor.

**ON** When the motorcycle is running the grip must be in the ON position to enable fuel to flow to the carburetor. The tank will drain completely in this position.

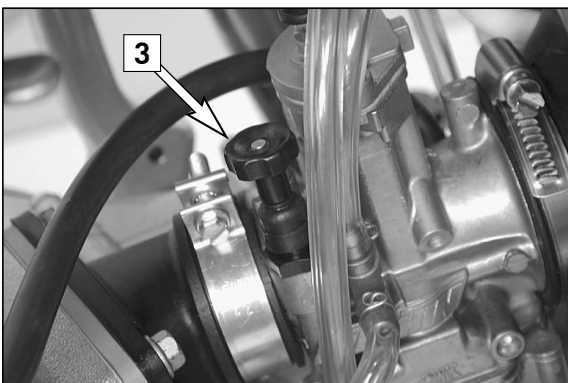

## Choke

The choke button [3] is located on the left side of the carburetor. Pulling the choke button [3] all the way out opens a bore in the carburetor through which the engine can take in additional fuel, thus achieving the "rich" fuel air mixture needed for cold starting.

Pushing the choke button back in closes the bore in the carburetor.

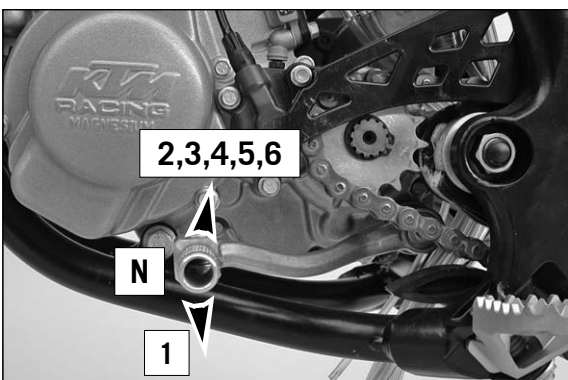

## Shift lever

The shift lever is mounted on the left side of the engine. The position of the gears is shown in the illustration. Neutral, or the idle speed, is located between first and second gear.





## Kickstarter

The kickstarter is mounted on the right side of the engine. Its upper part can be swivelled.

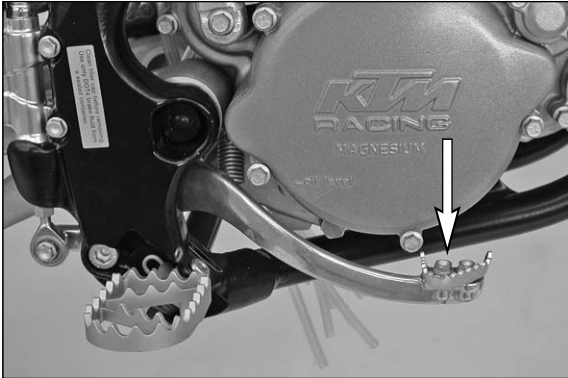

## Foot brake pedal

The foot brake pedal is located in front of the right foot rest. Its basic position can be adjusted to your seat position (see maintenance work).

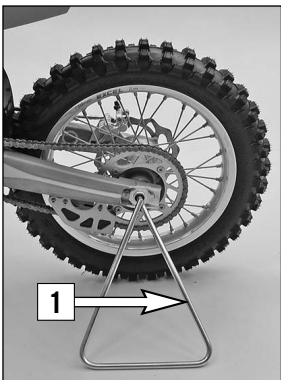

## Plug-in- Stand (SX)

The plug-in stand [1] included in the scope of supply can be plugged into the left side of the bike at the end of the swinging fork.

## Side Stand (XC):

Use your foot to swing the side stand forwards to the stop. Make sure it rests securely on solid ground.

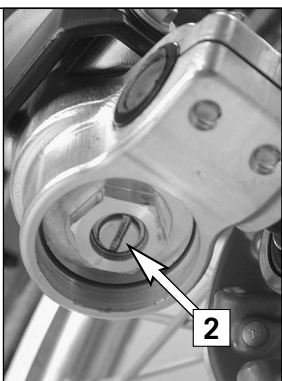
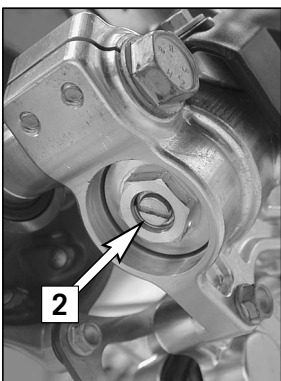

## Compression damping of fork

Hydraulic compression damping determines the reaction when the fork is compressed. The degree of compression can be adjusted with adjusting screws at the bottom of the fork legs. Remove the protecting cap. Turn the knob [2] clockwise to increase damping, turn it counterclockwise to reduce damping during compression.

### STANDARD ADJUSTMENT

- turn adjusting screw clockwise as far as it will go
- turn it back by as many clicks as are specified for the relevant type of fork

Type WP Suspension 05187E05  
Type WP Suspension 05187E06

15 clicks  
20 clicks

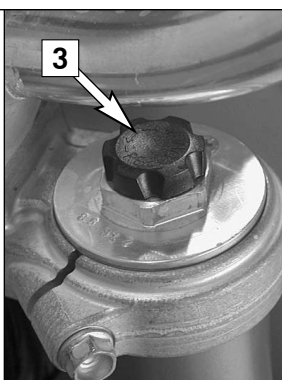
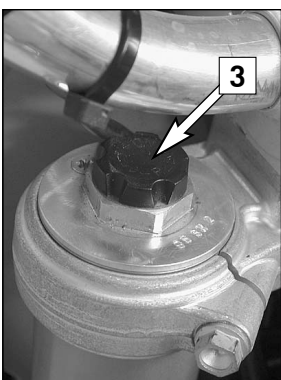

## Rebound damping of fork

Hydraulic rebound damping determines the reaction when the fork is rebound. By turning the adjusting screw [3] (REB), the degree of damping of the rebound can be adjusted. Turn the knob clockwise to increase damping, turn it counterclockwise to reduce damping during rebounding.

### STANDARD ADJUSTMENT

- turn adjusting screw clockwise as far as it will go
- turn it back by as many clicks as are specified for the relevant type of fork

Type WP Suspension 05187E05  
Type WP Suspension 05187E06

20 clicks  
20 clicks



## Damping action during compression of shock absorber

The shock absorber on the models can synchronize the compression damping in the low and high-speed range separately (Dual Compression Control).

Low and high speed refers to the movement of the shock absorber during compression and not to the speed of the motorcycle.

The low and high-speed technology overlaps.

The low-speed setting is primarily for slow to normal shock absorber compression rates. The high-speed setting is effective at fast compression rates. Turning in a clockwise direction will increase the damping, turning counterclockwise will decrease the damping.

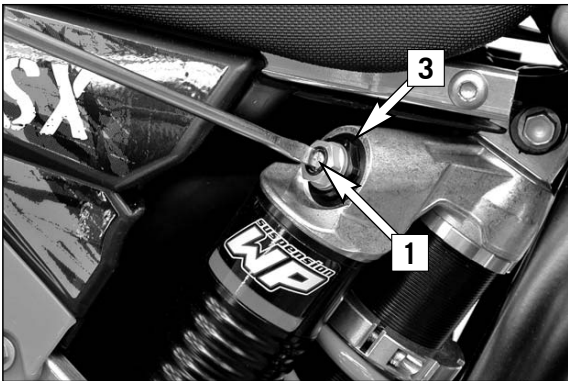

## Standard low-speed setting:

- Turn the adjusting screw [1] to the limit in a clockwise direction using a screwdriver.
- Unscrew the respective number of clicks for the specific type of shock absorber in a counterclockwise direction.

Type WP Suspension 15187E02	15 clicks
Type WP Suspension 15187E04	15 clicks



## Standard high-speed setting:

- Turn the adjusting screw [2] to the limit in a clockwise direction using a box wrench.
- Unscrew the respective number of turns for the specific type of shock absorber in a counterclockwise direction.

Type WP Suspension 15187E02	2 turns
Type WP Suspension 15187E04	2 turns

### **⚠ WARNING**

The damping unit of the shock absorber is filled with high-compression nitrogen. Never try to take the shock absorber apart or to do any maintenance work yourself. Severe injuries could be the result.

Never unscrew the black screw 3 connection (24mm).

## Rebound damping function of the shock absorber

By using the adjusting screw [4], the degree of damping of the rebound can be adjusted. Turn the knob clockwise to increase damping, turn it counterclockwise to reduce damping during rebounding.

### STANDARD ADJUSTMENT:

- turn the adjusting screw clockwise to the stop.
- then turn the adjusting screw counterclockwise, counting the number of clicks that corresponds to the respective type of shock absorber.

Type WP Suspension 15187E02	22 clicks
Type WP Suspension 15187E04	22 clicks

### **⚠ WARNING**

The damping unit of the shock absorber is filled with high-compression nitrogen. Never try to take the shock absorber apart or to do any maintenance work yourself. Severe injuries could be the result.

Never unscrew the black screw connection 5 (15mm).

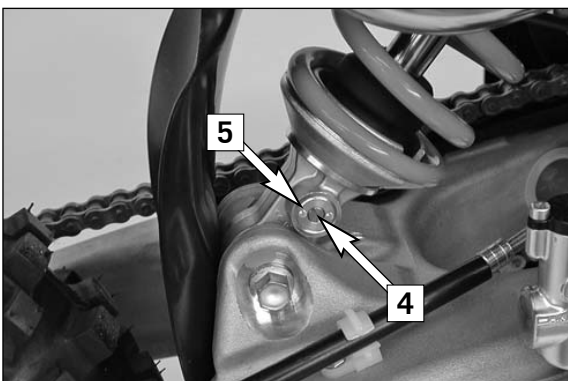



## Instructions for the first ride

- Make sure the work for the "pre-delivery inspection" was performed by your authorized KTM workshop. The DELIVERY CERTIFICATE and SERVICE MANUAL will be handed over when you pick up your vehicle.
- Before your youngster takes his or her first ride, explain how each of the controls works and check if your youngster has understood what you explained. We recommend to review the entire owner's manual with your youngster item by item, paying particular attention to the specially marked warnings and pointing out the danger of injury.
- Adjust the clutch lever, hand lever and foot brake pedal so your child can operate them easily!
- To prevent injury, teach your youngster the basic riding skills on soft ground, e.g. on a meadow or in the garden. Be sure that there is room enough to maneuver, and that no other riders are close.
- To ensure that your youngster gets the feel of the hand brake, have your youngster operate the hand brake while you push the motorcycle. Do not start the engine before your youngster has learned to apply hand brake with appropriate pressure.
- To familiarize your youngster with the operation of the hand brake let him or her practice to operate the hand brake while you are pushing the motorcycle. Do not start the engine before he or she is thoroughly familiar with the use of the hand brake.
- Initially, your youngster should ride back and forth between two persons who help the young rider to stop the motorcycle. However, you should also teach your youngster how to stop the motorcycle himself/herself.
- To improve his/her riding skills, your youngster should practice riding the motorcycle standing on the footpegs or to riding at the slowest possible speed. Additionally, you can arrange a series of obstacles and have your youngster drive around them, etc.
- Pay attention to the running-in procedure.

## Running in

- Even very precisely machined sections of engine components have rougher surfaces than components which have been sliding across one another for quite some time. Therefore, every engine needs to be broken in. For this reason, during its first 30 minutes the engine must not be revved up to its performance limits.
- Apply low but changing loads for running-in.
- **DO NOT DRIVE AT FULL LOAD FOR THE FIRST 30 MINUTES!**

## WARNING

- **Have your youngster wear proper protective gear whenever he or she rides the motorcycle: helmet, eye protection, chest, back, arm and leg protectors, gloves and boots. To set a good example, be sure to wear protective gear yourself whenever riding a motorcycle!**
- Only use accessory parts recommended by KTM.
- The front and rear wheel are only allowed to be tired with tires that have the same profile type.
- Your youngster's driving speed should always be adjusted to his/her driving skills as well as to the terrain.
- Your youngster should never be allowed to ride the motorcycle without supervision.
- Replace the helmet visor or goggle glasses early enough. When light shines directly on a scratched visor or goggles, you will be practically blind.
- Never leave your motorcycle without supervision as long as the engine is running.
- SX and XC models are designed for one person only. Passengers are not allowed.
- These models do not comply with the regulations and safety standards established by the law. Therefore, they are not permitted on public roads.
- Always keep in mind that other people feel molested by excessive noise.

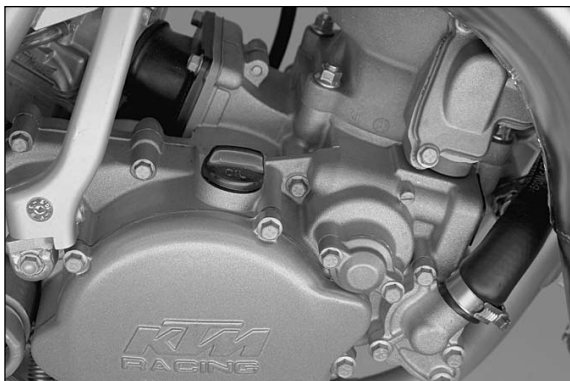

## What you should check before each start

When you start off, the motorcycle must be in a perfect technical condition. For safety reasons, you should make it a habit to perform an overall check of your motorcycle before each start.

The following checks should be performed:

### 1 CHECKING THE ENGINE

Check the engine for any oil leakage. Too little gear oil will lead to premature wear and consequently destroy the transmission.

### 2 FUEL

Check that there is sufficient fuel in the tank; when closing the filler cap, check that the tank venting hose is free of kinks.

### 3 CHAIN

A loose chain may fall off the chain wheels; an extremely worn chain may tear, and insufficient lubrication may result in unnecessary wear of the chain and chain wheels.

### 4 TIRES

Check for damaged tires. Tires showing cuts or dents must be replaced. Also check the air pressure. Insufficient tread and incorrect air pressure deteriorate the driving performance.

### 5 BRAKES

Check the correct functioning of the braking system. Verify that there is sufficient brake fluid in the reservoir. The reservoirs have been designed in such a way that brake fluid does not need to be refilled even when the brake pads are worn. If the level of brake fluid falls below the minimum value, this indicates a leak in the braking system or completely worn out brake pads. Always have the brake system checked by a KTM workshop to avoid brake failure.

Also check the state of the brake hose and the thickness of the brake linings. Check free travel at the hand brake lever and foot brake lever.

## ⚠ WARNING

**If the resistance in the hand brake lever feels “spongy” (too much play), this is an indication that something is wrong with the brake system. Don’t let your child ride the motorcycle anymore without first having the brake system looked over by a KTM dealer.**

### 6 CABLES

Check correct setting and easy running of all control cables.

### 7 COOLING FLUID

Check the level of cooling fluid when the engine is cold.

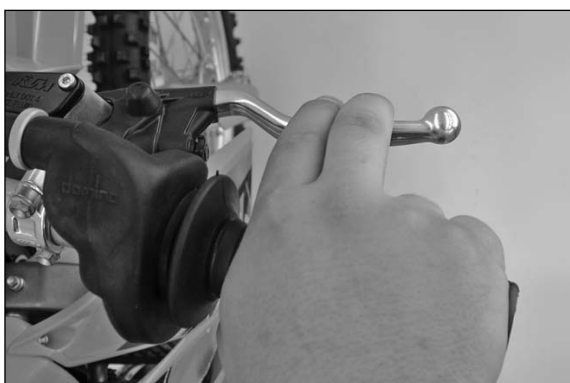
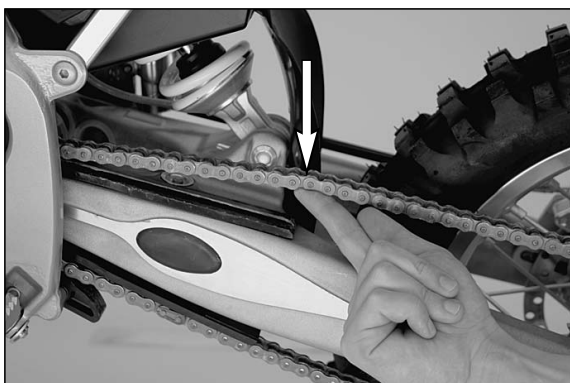

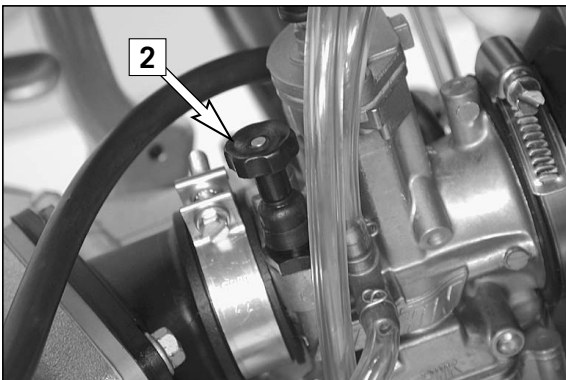
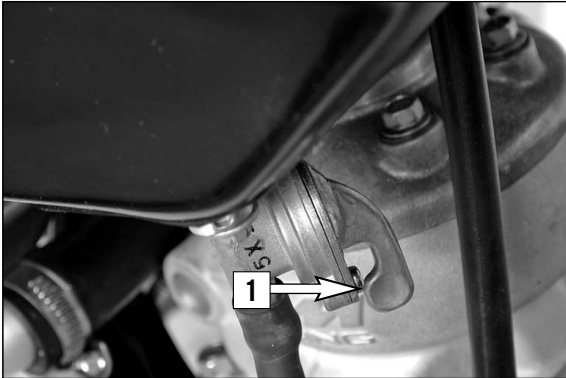

## Starting when the engine is cold

- 1 Open fuel tap [1].
- 2 Put the gear in neutral
- 3 Activate the cold-starting aid (choke) [2].
- 4 Leave throttle closed and kick down the kickstarter vigorously all the way.

### ⚠ WARNING

- To avoid injury when starting the engine, always wear strong bikers boots! You may slip off the kickstarter, or the engine may kick back if you do not kick hard enough.
- Check for power transmission at temperatures below 0°C (32°F) before you actuate the kickstarter. If you depress the kickstarter without feeling any resistance, power is not being transmitted. This could cause injuries.
- Do not start the engine and allow it to idle in a closed area. Exhaust fumes are poisonous and can cause loss of consciousness and death. Always provide adequate ventilation while the engine is running.

### ! CAUTION

Do not ride your motorcycle at full load and do not rev up the engine when cold. Since the piston warms up and expands faster than the water cooled cylinder, this might cause engine damage. Always let engine idle until warm or drive it warm at low r.p.m. speeds.

#### NOTE:

The highly inflammable components in modern fuels volatilize if left standing for longer periods of time. If the motorcycle has not been used for over 1 week, the fuel should be drained from the float chamber. The engine will start up immediately if the float chamber is filled with fresh, ignitable fuel

## Starting when the engine is warm

- 1 Open fuel tap
- 2 Put the gear in neutral
- 3 Leave throttle closed and kick down kickstarter vigorously all the way.

## What to do when the engine is “flooded“

- 1 Close fuel tap
- 2 Start engine with full throttle. If necessary, unscrew spark plug and dry it.
- 3 Once the engine is running, open fuel tap again.

## Starting off

Pull the clutch lever. Put the engine into first gear, slowly release the clutch lever and accelerate at the same time.

### ⚠ WARNING

Always make sure the side stand is kicked all the way up or the plug-in stand removed before you let your child drive off. The motorcycle could run out of control if the stand touches the ground.

## Shifting/Riding

You are now in first gear, referred to as the drive or uphill gear. Depending on the conditions (traffic, hill size, etc.), you can shift to a higher gear. Turn down the throttle, at the same time pull clutch lever in and shift to the next higher gear. Let clutch lever go again and open the throttle. If you turned on the choke, make sure you turn it off again as soon as engine is warm.



When shifting down, use the brakes if necessary and turn down at the same time. Pull clutch lever and shift down to the next lower gear. Let the clutch lever go slowly and open throttle or shift down again.

## ⚠ WARNING

- After falling with the motorcycle, check all its functions thoroughly before using it again.
- A twisted handlebar must always be replaced. Do not adjust the handlebar, it will lose stability.

## ! CAUTION

- Driving a cold engine at high speed will reduce the life of the engine. We recommend to warm the engine up at a medium engine speed for several minutes before switching to full load.
- Never have the throttle wide open when changing down to a lower gear. The engine will overrev, damaging the valves. In addition, the rear wheel blocks so that the motorcycle can easily get out of control.
- If the engine runs without throttle during longer downhill travel, the engine should be accelerated occasionally to ensure that it is supplied with sufficient lubricant which is mixed in the fuel.
- In the event that, while your child is riding on the motorcycle, you notice any unusual operation-related noise, your child should stop immediately, turn the engine off, and contact an authorized KTM dealer.

## Braking

Turn off the gas and apply the hand and foot brakes at the same time. When driving on sandy, wet or slippery ground use mainly the rear wheel brake. Always brake with feeling, blocking wheels can cause you to skid or fall. Also change down to lower gears depending on your speed.

## ⚠ WARNING

- In case of rain, after washing the motorcycle, after rides through water and in case of rides on wet off-road tracks, humid or dirty brake discs can delay the braking effect. The brakes must be pulled until they are dry or clean.
- Dirty brake discs cause increased tear of brake pads and brake discs.
- When you brake, the brake discs, brake pads, brake caliper and brake fluid heat up. The hotter these parts get, the weaker the braking effect. In extreme cases, the entire braking system can fail.

## Stopping

Brake motorcycle and shift gears to idling. To switch off the engine, depress short circuit switch until the engine stops. Close fuel tap.

## ⚠ WARNING

Motorcycle engines produce a great amount of heat while running. The engine, exhaust pipe, muffler, brake rotors, and shock absorbers can become very hot.

Do not touch any of these parts after starting the motorcycle, and take care to park it where pedestrians are not likely to touch it and get burned.

## ! CAUTION

- Close the fuel tap when leaving your vehicle. Otherwise the carburetor may get flooded and fuel will enter the engine.
- The plug-in stand is designed to hold the weight of the motorcycle only. By sitting on the motorcycle, your child will put additional weight on the plug-in stand, possibly causing the plug-in stand or swinging fork to be damaged or the motorcycle to fall down.

## Refueling, fuel

Oil (high-grade two-stroke engine oil; i.e. Motorex Cross Power 2T) must be mixed with the fuel (ROZ 95) at a mixing ratio of 1:40.

## ⚠ WARNING

Gasoline is highly flammable and poisonous. Extreme caution should be used when handling gasoline. Never refuel the motorcycle near open flames or burning cigarettes. Always switch off the engine before refueling. Be careful not to spill gasoline on the engine or exhaust pipe while the engine is hot. Wipe up spills promptly. If gasoline is swallowed or splashed in the eyes, seek a doctor's advice immediately.

## ! CAUTION

- Only use premium-grade gasoline ROZ 95 mixed with high-grade two-stroke engine oil. Other types of gasoline can cause engine failure.
- Only use known brands of high-grade 2-stroke engine oil (Motorex Cross Power 2T).
- Not enough oil or low-grade oil can cause erosion of the piston. When using too much oil, the engine may start smoking and foul the spark plug.
- Fuel expands when its temperature rises. Therefore do not fill the tank to the top. (see fig.)
- Do not use premixed two-stroke oils, oils for outboard engines or normal engine oil to prepare the mixture.
- Do not use gasoline and oil mixtures that are older than one week. The lubrication properties of some two-stroke oils can deteriorate very rapidly.

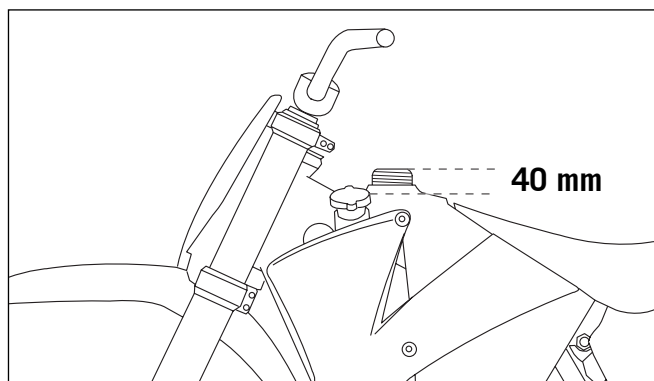

# PERIODIC MAINTENANCE SCHEDULE »

85/105 SX/XC 2009		before each race	1st service after 10 hours	every 20 hours	every 40 hours	at least once a year
<b>A CLEAN MOTORCYCLE CAN BE CHECKED MORE QUICKLY WHICH SAVES MONEY</b>						
<b>ENGINE</b>	Check gear box oil level			●		
	Change gear box oil	●	●		●	●
	Check spark plugs, adjust distance between electrodes		●	●		
	Renew spark plugs	●			●	
	Clean the spark-plug connector and check for a tight fit	●		●	●	
	Check the screws on the kick starter and shift lever for a tight fit	●		●	●	
<b>CARBURETOR</b>	Check the carburetor connection boot and intake flange for cracks or leaks	●			●	●
	Check idle speed setting	●	●		●	●
	Check that vent hoses are not damaged or bent	●	●		●	●
<b>ADD-ON-PARTS</b>	Check cooling system for leaks, check quantity of antifreeze	●	●		●	●
	Check exhaust system for leaks and fitment	●		●	●	
	Check cables for damage, smooth operation, bends; adjust and lubricate	●	●		●	
	Check the fluid level in the master cylinder of the hydraulic clutch	●	●	●	●	
	Clean air filter and filter box	●	●	●	●	●
	Check electric wires for damage and bends	●			●	
<b>BRAKES</b>	Check function of electric systems (emergency OFF switch)	●	●		●	
	Check brake fluid level, lining thickness, brake lining	●	●		●	
	Check brake lines for damage and leaks	●	●		●	
	Check/adjust smooth operation and free travel of handbrake/foot brake lever	●	●		●	
	Check the screws and guide bolts on the brake system for a tight fit	●	●		●	
<b>CHASSIS</b>	Check shock absorber and fork for leaks and function	●	●	●	●	
	Clean dust bellows	●		●	●	
	Bleed fork legs	●		●	●	
	Check swing arm bearings	●			●	
	Check/adjust steering head bearings	●	●		●	
	Check tightness of all chassis screws (triple clamps, fork leg axle passage axle nuts and screws, swing arm bearings, shock absorber)	●	●		●	
<b>WHEELS</b>	Check spoke tension and rim joint	●	●	●	●	
	Check tires and air pressure	●	●	●	●	
	Check chain, rear sprockets and chain guides for wear, fitment and tension	●	●	●	●	
	Lubricate chain, Clean and grease the adjusting screws on the chain tensioner	●	●	●	●	
	Check clearance of wheel bearings	●	●		●	

The kilometer reading for inspection intervals should not exceed 3 hours.

Maintenance work performed by your authorized KTM workshop is not a substitute for care and maintenance by the driver!

# PERIODIC MAINTENANCE SCHEDULE »

85/105 SX/XC 2009	Every 20 hours	Every 40 hours	At least once a year	Every 2 years
<b>IMPORTANT SERVICE WORK THAT MUST BE PERFORMED BY AN AUTHORIZED KTM WORKSHOP UNDER A SEPARATE ORDER</b>				
Clean and adjust carburetor			●	
Check the reed-type intake valve for wear	●	●		
Check the wear on the clutch disks and length of the clutch springs	●	●		
Check the cylinder and piston for wear	●	●		
Check function of exhaust control	●	●		
Check piston pin bearing	●			
Replace the crankshaft main bearings	●			
Replace the conrod bearings		●		
Check the entire transmission, the shift mechanism and bearings		●		
Complete maintenance of fork	●		●	
Complete maintenance of shock absorber				●
Clean and grease steering head bearings and gasket elements			●	
Replace the sealing cup for the foot brake cylinder	●	●		
Replace the glass-fiber yarn filling in the silencer	●	●		
Treat electric contacts and switches with contact grease			●	
Change break fluid	●	●	●	
Change hydraulic clutch fluid			●	
Change the hydraulic clutch oil				

**Note:** If the inspection establishes that permissible tolerances are exceeded, the respective components must be replaced.

85/105 SX/XC 2009	before each start	after every cleaning	for cross country use	once a year
<b>IMPORTANT CHECKS AND MAINTENANCE TO BE CARRIED OUT BY THE RIDER OR THE MECHANIC</b>				
Check gear box oil level	●			
Check brake fluid level	●			
Check brake pads for wear	●			
Lubricate and adjust cables and nipples		●		
Bleed fork legs regularly			●	
Remove and clean dust bellows regularly			●	
Clean and lubricate chain, check tension and adjust if necessary		●	●	
Clean air filter and filter box		●	●	
Check tires for pressure and wear	●			
Check cooling liquid level	●			
Check fuel lines for leaks	●			
Empty and clean float chamber		●		●
Remove, clean and oil the throttle slide		●		
Check all control elements for smooth operation	●			
Check brake performance	●	●		
Treat blank metal parts (with the exception of brake and exhaust systems) with wax-based anti corrosion agent		●		
Check tightness of screws, nuts and hose clamps regularly				●



## ⚠ WARNING

All maintenance and adjustment operations that are marked with an asterisk \* require specialist knowledge. For your own security, let these tasks be carried out by a ktm-dealer where your motorcycle will be optimally serviced by appropriately qualified, skilled staff.

## ! CAUTION

- When cleaning the motorcycle, do not use a high pressure cleaning unit if possible, otherwise water will penetrate the bearings, carburetor, electric connectors, etc.
- When transporting your KTM, ensure that it is held upright with restraining straps or other mechanical fastening devices and that the fuel tap is in the OFF position - if the motorcycle should fall over, no fuel can leak from the carburetor or fuel tank
- Only use special screws with an appropriate thread length supplied by KTM to fix the spoilers on the tank. Using other screws or longer screws can cause leaks in the tank through which fuel can flow out.
- Do not use toothed washers or spring rings with the engine fastening screws, as these work into the frame parts and keep working loose. Instead, use self-locking nuts.
- Let your motorcycle cool down before beginning any maintenance work in order to avoid getting burned.
- Dispose of Oils, fatty matters, filters, fuels, washing detergents, etc. properly.
- Under no circumstances may used oil be disposed of in the sewage system or in the open countryside. 1 liter of used oil contaminates 1,000,000 liters of water.

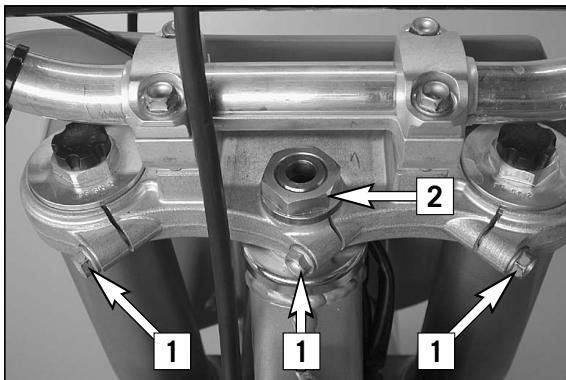

### Checking and adjusting the steering head bearing \*

Check steering head bearing for play periodically. To check, put motorcycle on the stand so that the front wheel is off the ground. Now try to move the fork forward and backward. For readjusting, loosen the three clamp screws [1] of the top triple clamp and turn steering stem bolt [2] clockwise until there is no more play. Don't tighten the steering stem bolt all the way, otherwise the bearings will be damaged. With a plastic hammer, lightly rap on the triple clamp to release tension. Retighten the three clamp screws to 25 Nm.

## ⚠ WARNING

If the steering head bearing is not adjusted to be free of play, the motorcycle will exhibit unsteady driving characteristics and can get out of control.

## ! CAUTION

If you drive with play in the steering head bearing for longer periods, the bearings and subsequently the bearing seats in the frame will be destroyed.

The steering head bearings should be regreased at least once a year (i.e. Motorex Fett 2000).

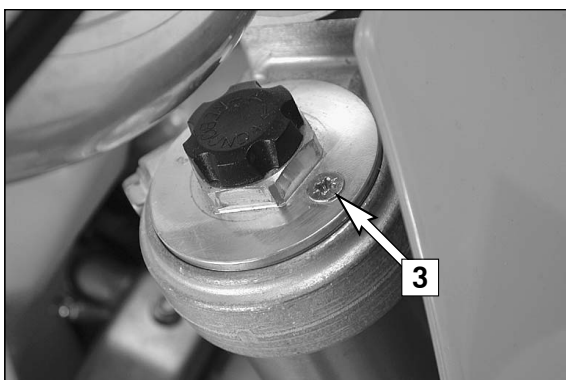
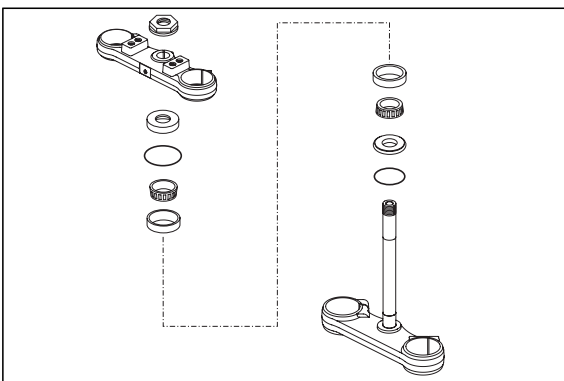

### Breather plug front fork

After every 5 hours of use for competitive racing, slacken the breather plugs [3] a few turns in order to relieve excess pressure from the inside of the fork. To do this, place the motorcycle on a stand with the front wheel lifted off the ground.

## ! CAUTION

Excessive pressure in the interior of the fork can cause leaks in the fork. If your fork is leaking, it is recommended to open the breather plugs before having the seals replaced.

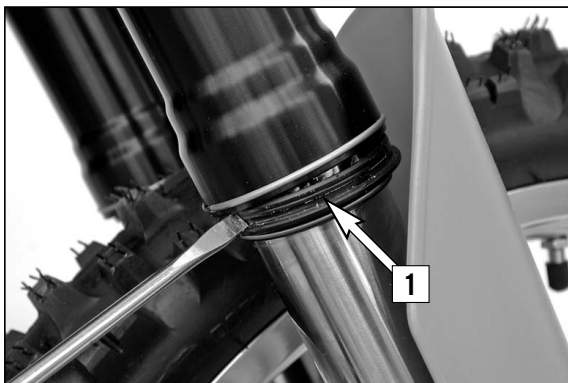

## Cleaning the dust sleeves of the telescopic fork

The dust-protection bellows [1] are to remove dust and coarse dirt particles from the fork tube. However, after some time, dirt may also get in behind the dust-protection bellows. If this dirt is not removed, the oil sealing rings located behind it may start to leak.

Use a screwdriver to lift the dust-protection bellows out of the outer tubes and slide them downward.



Clean dust-protection bellows, outer tubes, and fork tubes thoroughly, and oil them thoroughly with oil-spray (Motorex Joker 440) or engine oil. Then, push dust-protection bellows into the outer tubes by hand.

### ⚠ WARNING

No oil may reach the front tire or the brake disks since this would considerably reduce the tire's road grip and the braking effect of the front brake.

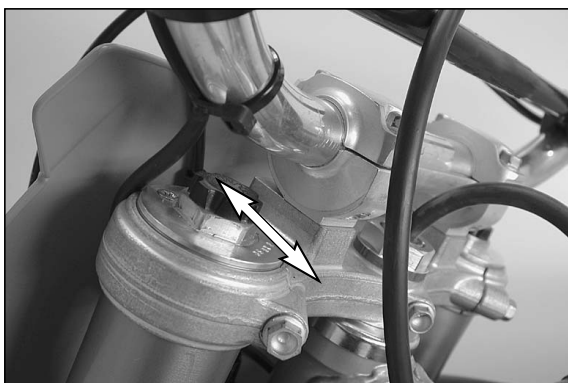

## How to change the handlebar position

The handlebar position can be readjusted by 22 mm. Thus, you can put the handlebar in the position that is the most convenient for you. The upper triple clamp [2] includes 2 bores arranged at a distance of 15 mm (0.6 in) from one another. The bores at the handlebar support [3] are offset from the center by 3.5 mm (0.13 in). Accordingly, you can mount the handlebar in 4 different positions.

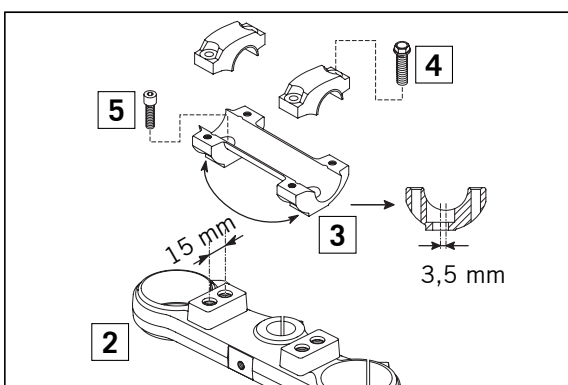

For this purpose, remove screws [4] of the handlebar clamps and screws [5] of the handlebar support. Position handlebar support, and tighten screws [5] to 40 Nm. Mount handlebar and handlebar clamps, and tighten screws [4] to 20 Nm. The gap between the handlebar support and handlebar clamps should be the same size in the front and in the rear.

### ⚠ WARNING

The screws [5] must be secured with loctite 243.

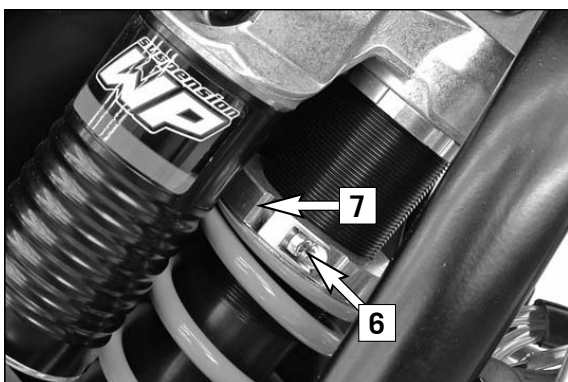

## Changing the spring preloading of the shock absorber

The spring preload can be changed by turning the adjusting ring [7]. For this purpose, you should dismount the shock absorber and clean it thoroughly.

NOTE:

- Before changing the spring preload note down the basic setting, e.g. how many threads are visible above the adjusting ring.
- One rotation of the adjusting ring [6] changes the spring pretension by approximately 1.75 mm (0.07 in).

Loosen the clamping screw [7] and use the hook wrench contained in the vehicle tool set to turn the adjusting ring as desired. Turning it counterclockwise will reduce the preload, turning it clockwise will increase the preload. After readjusting the clamping screw [6], tighten it to 5 Nm (6 ft.lb).

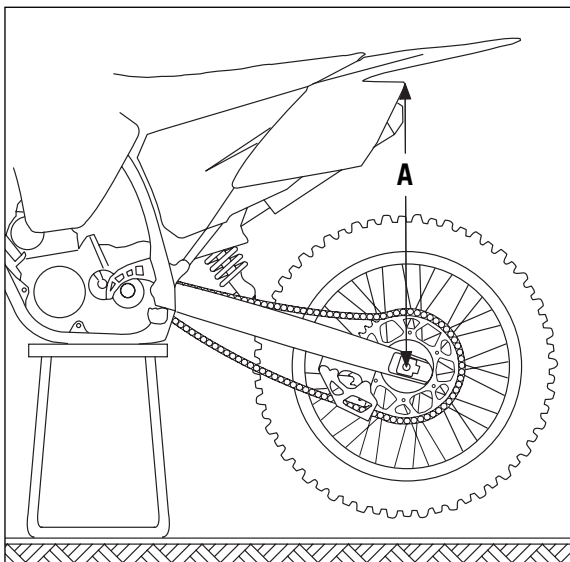

### Basic suspension setup for the weight of the driver

To achieve maximum handling performance and to prevent the fork, shock absorber, swing arm and frame from being damaged, the basic setup of the suspension components must be suitable for your child's weight. At delivery, the fork and shock absorber are set to accommodate a driver weighing between 45 and 55 kg (wearing full protective clothing). If your child's weight exceeds or falls short of this range, you will need to adjust the spring components accordingly.

Minor deviations in weight can be compensated by adjusting the spring preload on the shock absorber. Other springs must be mounted on the fork and shock absorber for larger deviations.

### Checking the shock absorber and spring

You can establish whether or not the shock absorber spring is suitable for your child's weight by checking the riding sag. The static sag must be correctly adjusted before the riding sag can be determined.

### Determining the static sag of the shock absorber

The static sag should be between 30 and 35 mm. Larger deviations can strongly influence the motorcycle's performance.

Procedure:

- Jack up the motorcycle until the rear wheel no longer touches the ground.
- Measure the vertical distance between the rear wheel axle and a fixed point (e.g. a mark on the side cover) and write it down as dimension A.
- Place the motorcycle on the ground again.
- Ask a helper to hold the motorcycle in vertical position.
- Measure the distance between the rear axle and the fixed point again to establish dimension B.
- The static sag is the difference between dimensions A and B.

EXAMPLE:

Motorcycle jacked up (dimension A) . . . . .	.600 mm
Motorcycle on ground, unloaded (dimension B) . . . . .	<u>565 mm</u>
Static sag . . . . .	.35 mm

If the static sag is lower, the spring preload of the shock absorber must be increased, if the static sag is reduced, the spring preload must be higher. See chapter "Changing the spring preload of the shock absorber."

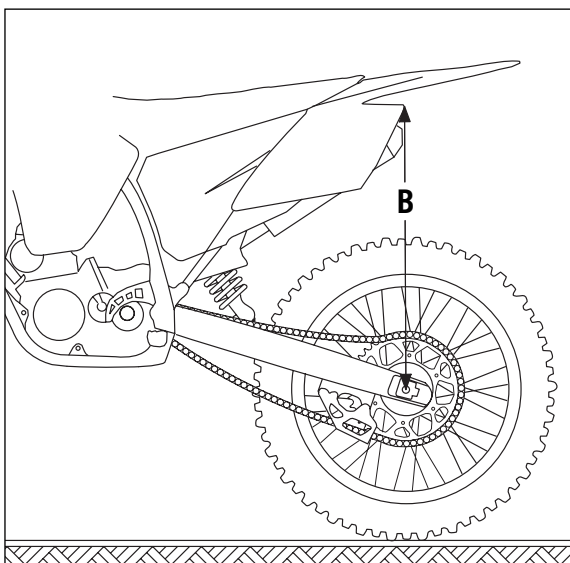

### Determining the riding sag of the shock absorber

- Have a helper hold the motorcycle. Your child should sit on the bike in a normal seating position (feet on the footrests) and bounce up and down a few times to allow the rear wheel suspension to become level.
- With your child on the bike, measure the distance between the same two points and write it down as dimension C.
- The riding sag is the difference between dimensions A and C.

EXAMPLE:

Motorcycle jacked up (dimension A) . . . . .	.600 mm
Motorcycle on ground, loaded (dimension C) . . . . .	<u>500 mm</u>
Riding sag . . . . .	.100 mm

The riding sag should lie between 95 and 105 mm. If the riding sag is less than 95 mm, the spring is too hard (the spring rate is too high). If the riding sag is more than 105 mm, the spring is too soft (the spring rate is too low).

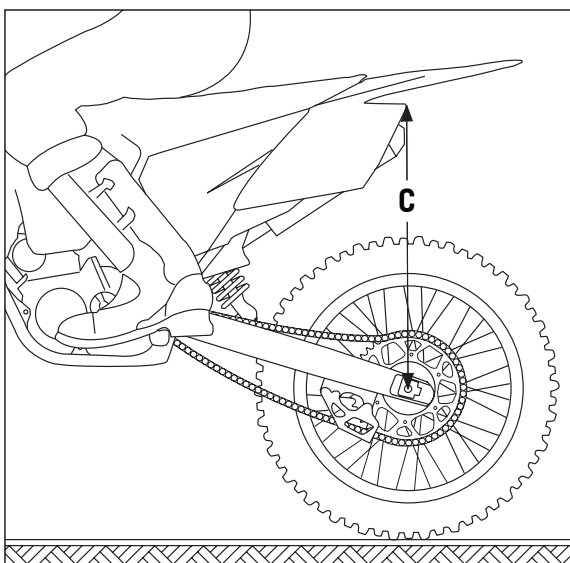

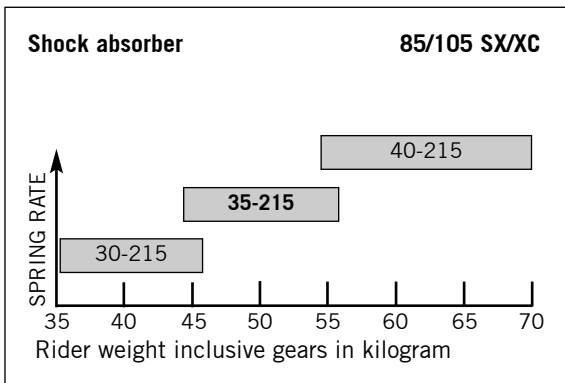

## Overview of the shock absorber springs

The spring rate is written on the outside of the spring (e.g. 35-215). The type number of the shock absorber is embossed on the top.

The illustration on the left shows which spring should be installed. The standard spring is shown in bold print.

After installing a different spring, readjust the static sag to 30-35 mm.

According to our experience, the damping rate of the compression stage can remain unchanged. The damping rate of the rebound stage can be reduced by a few clicks for a softer spring or increased by a few clicks for a harder spring.

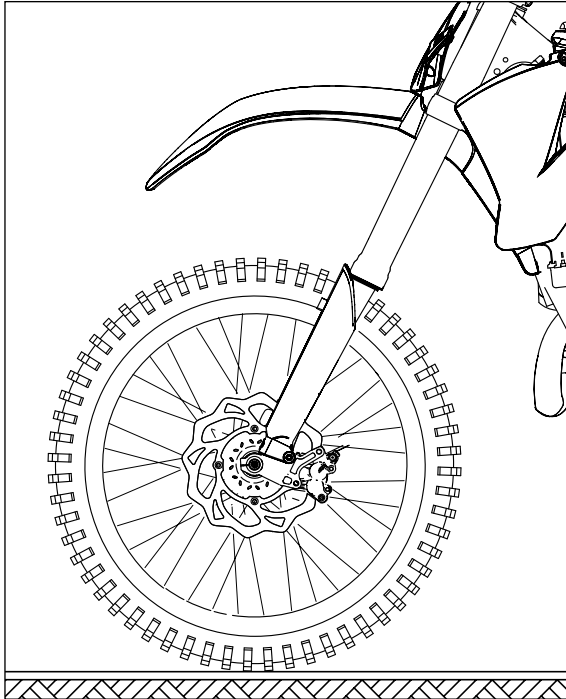

## Checking the basic setup of the telescopic fork

The precise riding sag of the telescopic fork cannot be determined for various reasons. If your telescopic fork bumps frequently (hard end stop during compression), you should install harder fork springs to avoid damaging the telescopic fork and frame.

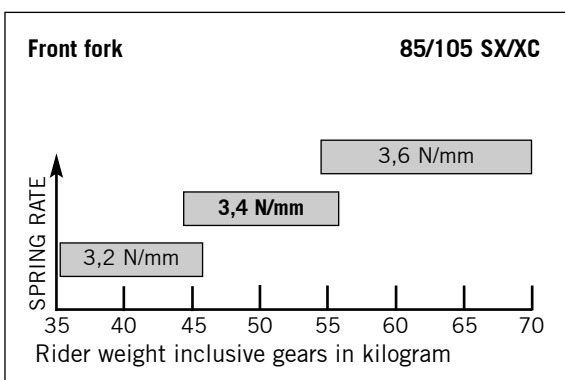

## Overview of the telescopic fork springs

If your child weighs less than 45 kg or more than 55 kg, have your KTM workshop mount suitable fork springs. The illustration on the left shows the correct spring rate. The standard spring is shown in bold print.

The type number of the telescopic fork is embossed on the inside of the fork leg.

According to our experience, the damping rate of the compression stage can remain unchanged. The damping rate of the rebound stage can be reduced by a few clicks for a softer spring or increased by a few clicks for a harder spring.

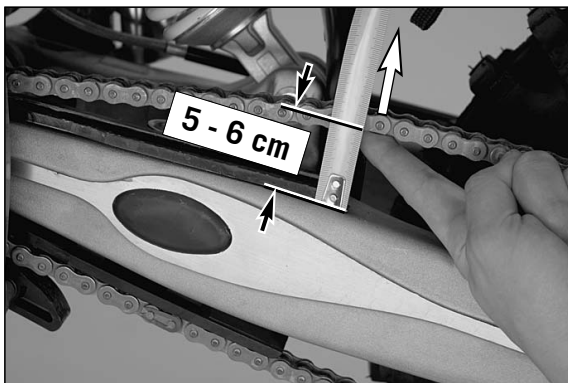

## Checking chain tension

Support the motorcycle on the center stand or side stand, respectively. Switch transmission to neutral. Push the chain upwards from the end of the chain sliding component until the upper part of the chain is tensioned. The distance between the chain and the swing arm should be 5 - 6 cm. The lower part of the chain should be tightened. Correct chain tension, if necessary!

### ⚠ WARNING

- If the chain is too tight the secondary transmission components (chain, sprockets, bearings of the transmission and of the rear wheel) will be put under additional strain that can, in addition to premature wear, also cause chain breakage.
- If the chain is not tight enough it can slip off the sprockets and block the rear wheel or damage the engine.
- In both cases the rider is very likely to lose control of the motorcycle.

## Correct chain tension

Loosen collar nut [1], loosen lock nuts [2], and turn right and left adjusting screws [3] equally far. Tighten lock nuts.

Before tightening the collar nut, verify that the chain adjusters [4] are sitting close to the adjusting screws and that the rear wheel has been aligned with the front wheel.

Tighten collar nut [1] to 80 Nm (60 ft.lb).

### ⚠ WARNING

- If you don't happen to have a torque wrench at hand, make sure you have the tightening torque corrected by a KTM dealer as soon as possible. A loose axle may lead to an unstable driving behavior of your motorcycle.
- Tighten the collar nut with the required torque.

### NOTE:

The large adjusting range of the chain adjusters (32mm) allows you to use different secondary ratios in combination with the same chain length. The chain adjusters [4] can be rotated by 180°.

### ! CAUTION

Always mount the chain tensioner equally aligned.

## Chain maintenance (SX)

For long chain life, good maintenance is very important. The chain should be cleaned in fireproof solvent regularly and afterwards treated with hot grease or chain spray (Motorex Chainlube 622).

## Chain maintenance (XC)

Maintenance of the O-ring chain is reduced to a minimum. Rinse off any heavy dirt with plenty of water. Residual used grease must be removed prior to lubrication (Motorex Chain Clean 611). After drying, use a chain spray specially designed for O-ring chains (Motorex Chainlube 622).

### ⚠ WARNING

No lubrication is allowed to reach the rear tire or the brake disks, otherwise the road adherence and the rear wheel braking effects would be strongly reduced and the motorcycle could easily lose control.

### ! CAUTION

When mounting the chain masterlink clip, the closed side of the masterlink clip must point in running direction.

Also check sprockets and chain guides for wear, and replace if necessary.

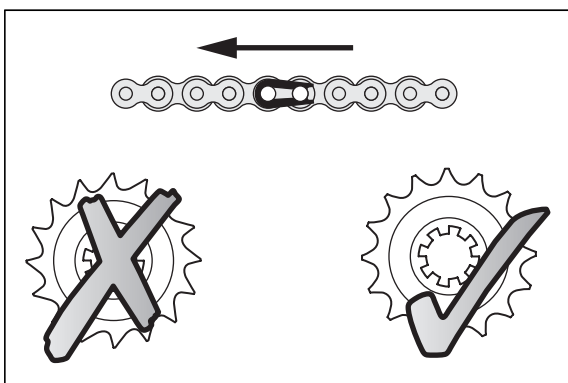
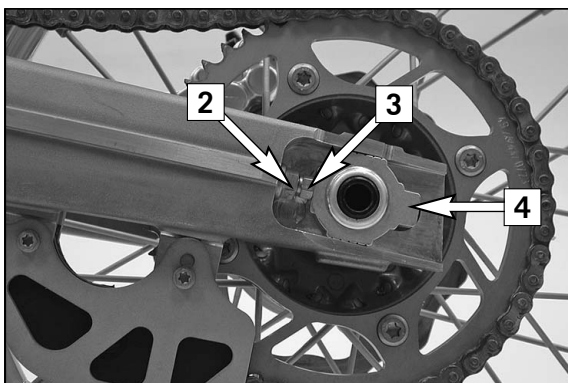
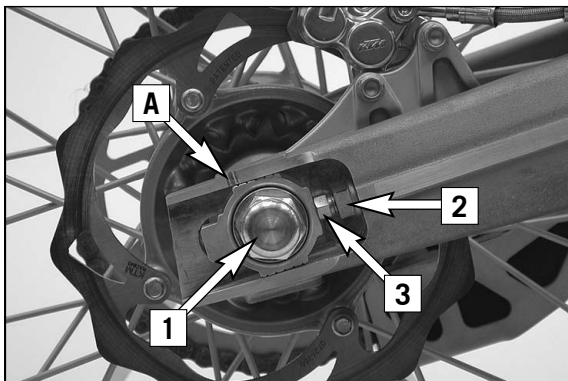



## General information about KTM disc brakes

### BRAKE CALIPERS:

If the front brake caliper is removed, the screws must be secured with Loctite 243 when mounted and tightened to 25 Nm.

### BRAKE FLUID RESERVOIRS:

The brake fluid reservoirs on front and rear wheel brakes have been designed in such a way that even if the brake pads are worn it is not necessary to top up the brake fluid. If the brake fluid level drops below the minimum level either the brake system has a leak or the brake pads are completely worn. In this case, consult an authorized KTM dealer immediately.

### BRAKE FLUID:

We recommend that you use Motorex DOT 5.1 brake fluid when you refill or change the brake fluid. DOT 5.1 brake fluid has a wet boiling point of 180°C / 356°F (25°C / 45°F higher than DOT 4) and is safer for high performance applications. Brake fluid DOT 5.1 is a polyethylene glycol based fluid, amber-colored and can be mixed with DOT 4 brake fluid. **Do not, in any event, use DOT 5 brake fluid.** It is based on silicone oil and is dyed purple. KTM motorcycle gaskets and brake hoses are not designed for DOT 5 brake fluid.

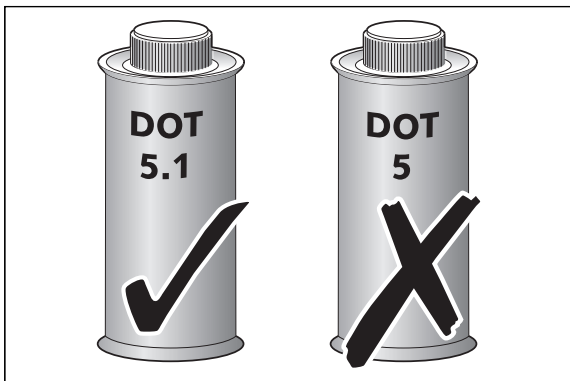

### ⚠ WARNING

Have the brake fluid changed at least once annually. If you wash your motorcycle often, the brake fluid should be changed even more frequently. Brake fluid tends to absorb water. Therefore, vapor pockets may form in "old" brake fluids even at low temperatures, causing the brake system to fail.

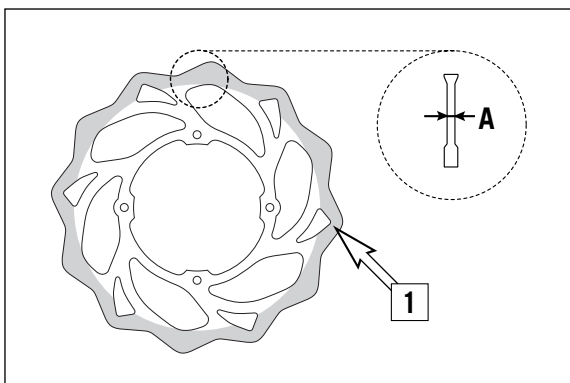

### BRAKE DISCS:

Due to wear, the thickness of the brake disc in the area of the contact face [1] of the brake pads decreases. The brake disk must be at least 2.50 mm (front) / 3.50 mm (rear) thick at the thinnest point [A]. Check the thickness of the brake disk at several points.

### ⚠ WARNING

- A brake disk worn down to less than 2.50 mm (Front) / 3.50 mm (Rear) is a safety risk. Have the brake disk replaced as soon as it reaches the service limit.
- Have any repairs on the brake system be performed by a KTM dealer.

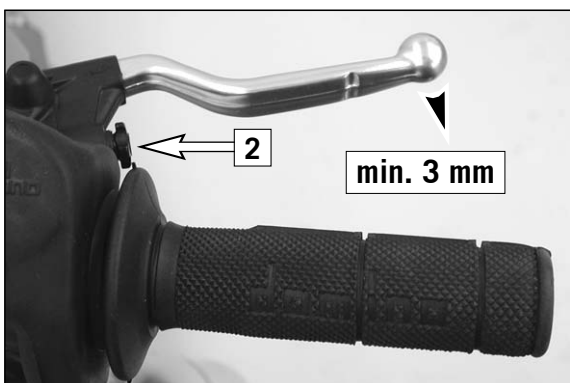

## Adjusting free travel of the hand brake lever

Free travel of the hand brake lever may be readjusted by using the adjustment screw [2]. In this way, the position of the point of pressure (i.e. the resistance you feel on the hand brake lever when the brake pads are pressed against the brake disc) can be adjusted for any hand size.

### ! CAUTION

At the hand brake lever, free travel must at least be 3 mm (0.1 in). Only then may the piston in the hand brake cylinder be moved (to be recognized by the greater resistance of the hand brake lever). If this free travel is not provided, pressure will build up in the braking system, and the front-wheel brake may fail due to overheating.

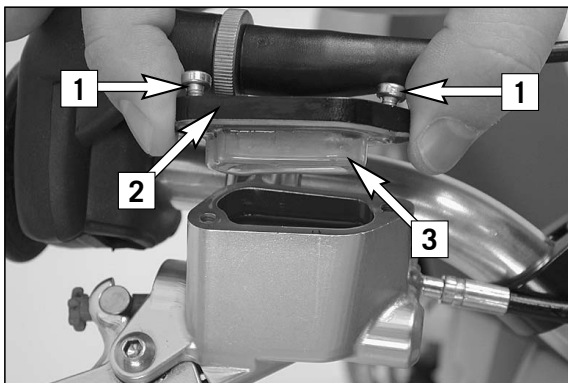

## Checking the brake fluid level/ refilling \*

The brake fluid reservoir is combined with the hand brake cylinder on the handlebar. To check the brake fluid level, press the brake pistons back into the basic position. Move the hand brake cylinder in a horizontal position, remove the screws [1] and the cover [2] with the diaphragm [3]. The brake fluid level should be 5 mm below the upper edge of the reservoir (see drawing), otherwise add DOT 5.1 brake fluid (e.g. Motorex Brake Fluid DOT 5.1) up to 5 mm below the upper edge of the reservoir.

Mount the diaphragm, the cover and the screws and actuate the hand brake lever until you feel the point of pressure again. Wipe off any overflowing or spilled brake fluid with water.

### ⚠ WARNING

- Actuate the hand brake lever until you feel the point of pressure again.
- Never use DOT 5 brake fluid! It is based on silicone oil and of a purple color. Seals and brake hoses must be especially adapted to it.
- Store brake fluid out of reach of children.
- Brake fluid can cause skin irritation. Avoid contact with skin and eyes. If you get brake fluid in your eyes, rinse with plenty of water and consult a doctor.

### ! CAUTION

- Don't let brake fluid get in contact with paint, it is an effective paint remover.
- Use only clean brake fluid taken from a tightly sealed container.

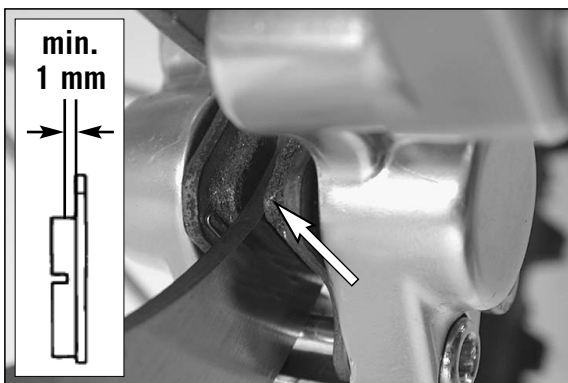
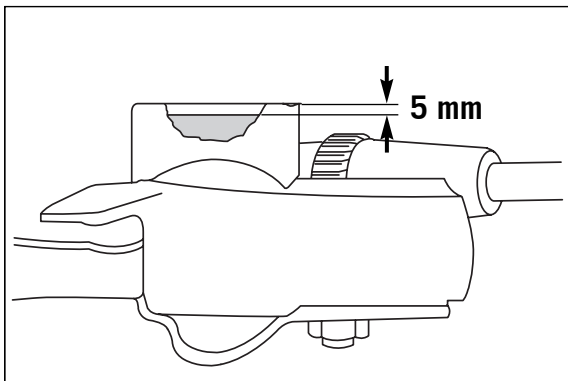

## Checking front brake pads

Inspect the brake pads from in front of the vehicle. The linings must be at least 1 mm (0.04 in) thick.

### ⚠ WARNING

At their most worn point brake pad linings should not be thinner than 1 mm (0.04 in), otherwise they could lead to brake failure. For your own safety don't put off having your brake pads changed.

### ! CAUTION

If the brake pads are replaced too late so that the lining is partly or entirely worn, the steel components of the brake pad will rub against the brake disc, thereby impairing the braking effect and destroying the brake disc.

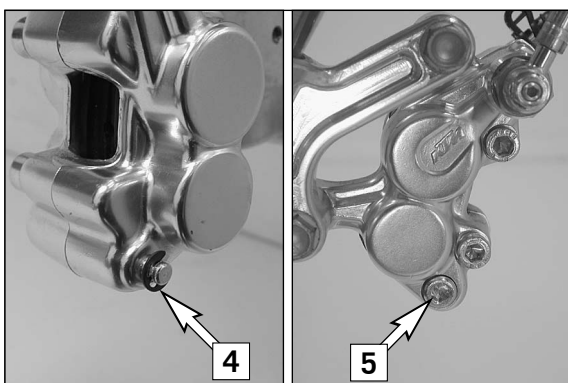

## Replacing the front brake pads \*

Remove the front wheel (see front wheel chapter).

Press brake shoes apart with a suitable screwdriver to put the brake pistons in their basic position.

Remove the lock washer [4] from the screw as well as fixing screw [5] and take the brake shoes out of the brake caliper. Clean brake caliper thoroughly with compressed air.



Mount the right brake shoe and fix with screw. Mount the left brake shoe and tighten the screw to 4 Nm. Mount the lock washer. Align brake shoes, mount front wheel (see chapter: Mounting the front wheel).

### ⚠ WARNING

- It is very important to keep the brake disk free from oil and fatty matters. Otherwise, the braking effect would be strongly reduced.
- After assembly, check if circlips have been fitted correctly.
- Do not unscrew any other screws on the brake caliper or you will have to bleed the brake system.
- After working on the brake system always operate the hand brake lever to apply the brake pads to the brake disk and create a point of pressure.

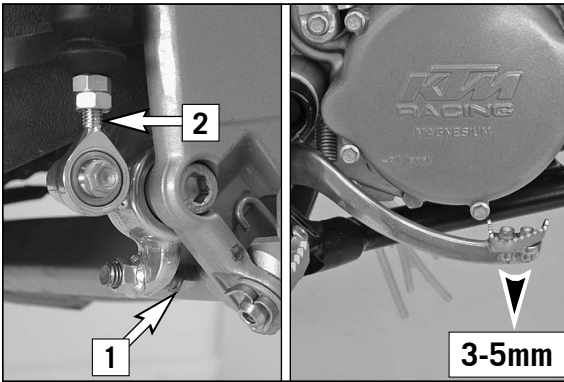

## Changing basic position of the brake pedal \*

The basic setting of the foot brake pedal can be changed by turning the end stop roller [1]. Using the push rod [2], the free play on the foot brake pedal must be set.

Measured on the outside, the foot brake pedal must have 3-5 mm of free play before the push rod can move the piston in the brake cylinder (to be recognised from the resistance on the foot brake pedal).

### ⚠ WARNING

If this clearance is missing, pressure accumulates in the braking system and the brake pads begin to rub. The braking system overheats and can fail completely in extreme cases.

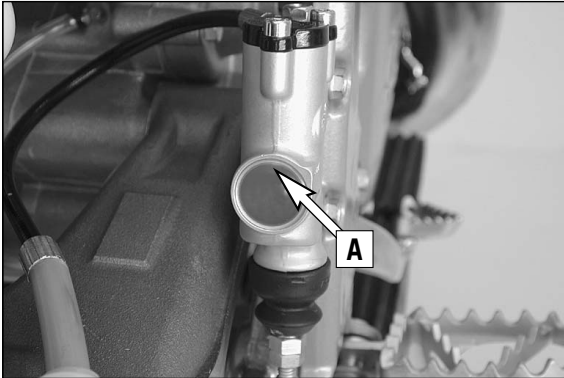

## Checking the rear brake fluid level

The reservoir for the rear disk brake is on the right side of the motorcycle on the rear brake cylinder.

The brake fluid level may not drop below the upper edge A of the inspection glass when the bike is in a horizontal position.

### ⚠ WARNING

If the brake fluid level drops below the upper edge of the inspection glass, this indicates that the brake system is either leaking or the brake shoes completely worn.

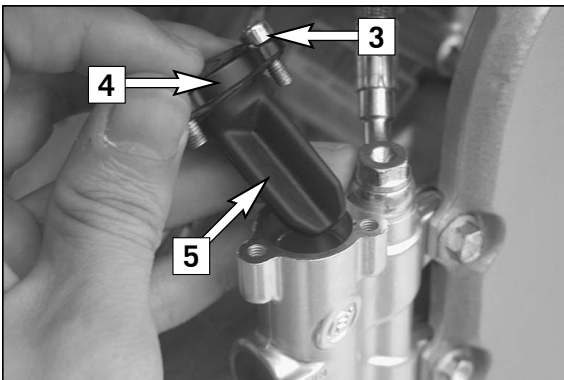

## Refilling the rear brake fluid reservoir \*

Remove the screws [3] and take off the cover [4] and diaphragm [5]. The brake pistons must be pushed back to their basic position. Fill DOT 5.1 brake fluid (e.g. Motorex Brake Fluid DOT 5.1) up to 10 mm (0.4 in) under the upper edge of the reservoir.

Remount the diaphragm, cover and screws and actuate the foot brake lever until you feel the point of pressure again. Wipe any overflowing or spilled brake fluid off with water.

### ⚠ WARNING

- Actuate the foot brake lever until you feel the point of pressure again.
- Never use DOT5 brake fluid! It is based on silicone oil and of a purple color. Seals and brake hoses must be especially adapted to it.
- Store brake fluid out of reach of children.
- Brake fluid can cause skin irritation. Avoid contact with skin and eyes. If you get brake fluid in your eyes, rinse with plenty of water and consult a doctor.

### ! CAUTION

- Don't let brake fluid get in contact with paint, it is an effective paint remover.
- Use only clean brake fluid taken from a tightly sealed container.

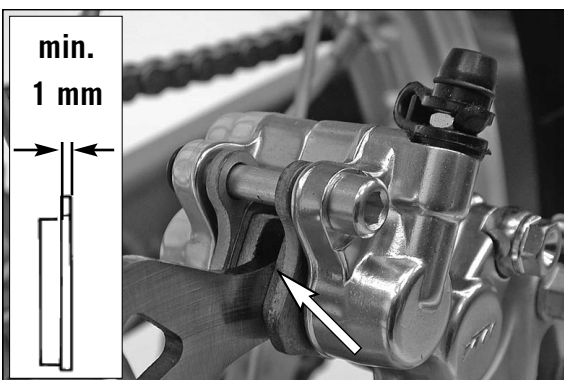
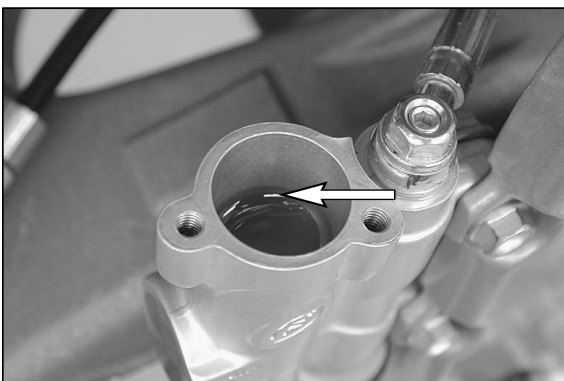

## Checking rear brake pads

The brake pads can be inspected from the rear. The thickness of the linings may not be less than 1 mm (0.04 in).

### ⚠ WARNING

At their most worn point brake pad linings should not be thinner than 1 mm, otherwise they could lead to brake failure. For your own safety don't put off having your brake pads changed.

### ! CAUTION

If the brake pads are replaced too late so that the lining is partly or entirely worn, the steel components of the brake pad will rub against the brake disc, thereby impairing the braking effect and destroying the brake disc.



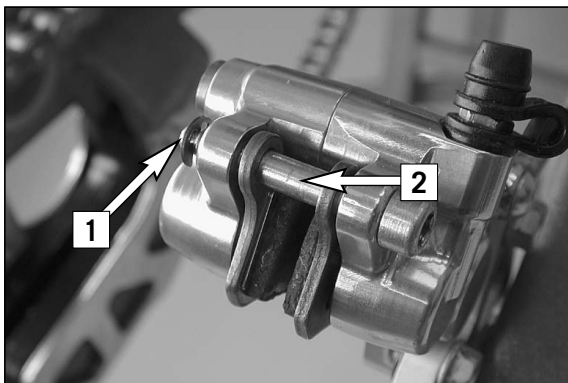

Remove the safety device [1], knock out the guide pin [2] from the brake caliper with a drift towards the chain wheel and remove the brake pads. Carefully clean the brake caliper with compressed air and check the sleeves of the guide pins for damage.

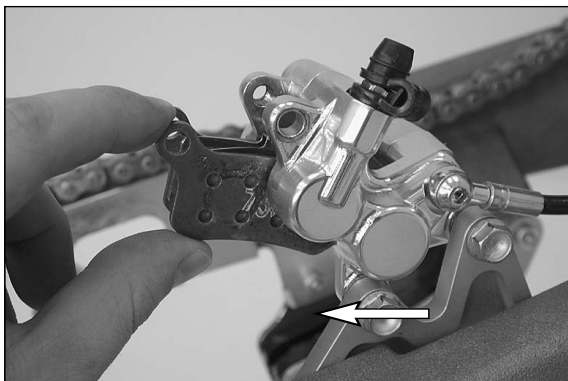

Press both brake shoes into the brake caliper and fix with bolt [2]. Mount the locks [1]. Tighten bolt [2] to 5 Nm (3,7 ft.lb).

## ⚠ WARNING

- It is very important to keep the brake disk free from oil and fatty matters. Otherwise, the braking effect would be strongly reduced.
- After assembly, check if circlips have been fitted correctly.
- After working on the braking system, one must always actuate the hand brake lever or foot brake lever, respectively so as to ensure that the brake pads will lie against the brake disk and the pressure point is established.

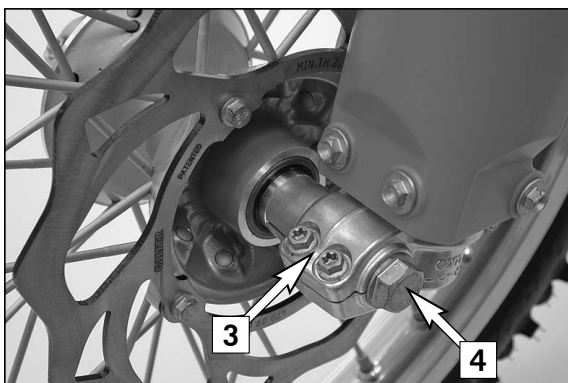

## Dismounting and mounting the front wheel

To remove the front wheel, jack the motorcycle up on its frame so that the front wheel no longer touches the ground.

Loosen the 2 clamping screws [3] on the left side of the fork fists.

Loosen and remove the collar nut [4], loosen the clamping screws [5] on the right side of the fork fist.

Hold the front wheel, pull out the wheel spindle [6].

Carefully remove the front wheel from the fork.

## ! CAUTION

- Do not operate the hand brake when the front wheel has been dismantled.
- Make sure the brake disc is always on top when you lay down the wheel, otherwise the brake disc can be damaged.

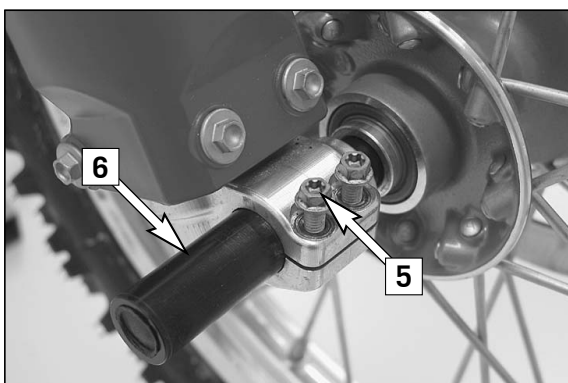

To install the front wheel, lift it into the fork, position and mount the axle shaft. Mount the collar nut [4], tighten the clamping screws [5] on the right fork leg axle passage to prevent the axle shaft from turning and tighten the collar nut to 40 Nm (29,52ft.lb).

Loosen the clamp screws on the right fork leg. Take the motorcycle down from its stand. Press the front wheel brakes and push down on the fork a few times vigorously so that the fork legs come into alignment.

Only after this has been accomplished, tighten the clamp screws on both fork legs with 10Nm (7ft.lbs)

## ⚠ WARNING

- If you don't happen to have a torque wrench at hand, make sure you have the tightening torque corrected by a KTM dealer as soon as possible. A loose axle may lead to an unstable driving behavior of your motorcycle.
- Tighten the hexagon nut with the required torque. A loose wheel spindle may lead to an unstable behavior of your motorcycle.
- After mounting the front wheel, keep operating the hand brake until the pressure point returns.
- It is very important to keep the brake disk free from oil and fatty matters, otherwise the braking effects would be strongly reduced.

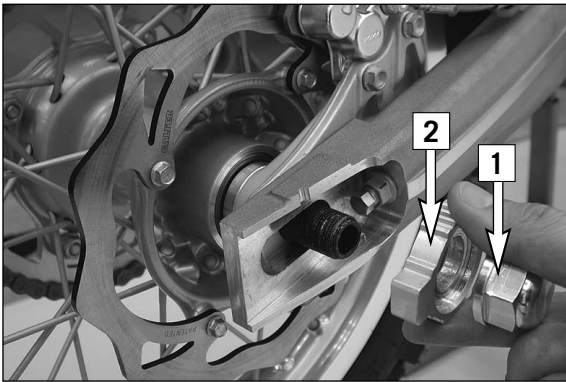

## Dismounting and mounting the rear wheel

Jack the motorcycle up on its frame so that the rear wheel no longer touches the ground.

Remove the collar nut [1], remove the chain tensioner [2] and pull out the wheel spindle [3] until you can push the rear wheel forwards.

Push the rear wheel as far forward as possible, take the chain from the chain wheel and carefully take the rear wheel out of the swingarm.

### ! CAUTION

- Do not operate the rear brake when the rear wheel has been dismantled.
- Make sure the brake disc is always on top when you lay down the wheel, otherwise the brake disc can be damaged.
- If the axle is dismantled, clean the thread of the wheel spindle and collar nut thoroughly and apply a new coat of grease to prevent the thread from jamming.

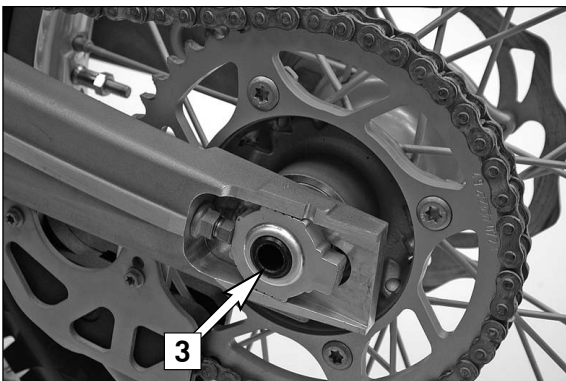

The rear wheel is remounted in the reverse order. Before tightening the collar nut to 80 Nm (60 ft.lb), push the rear wheel forwards so that the chain tensioners lie on the tension screws.

### ⚠ WARNING

- If you don't happen to have a torque wrench at hand, make sure you have the tightening torque corrected by a KTM dealer as soon as possible. A loose axle may lead to an unstable driving behavior of your motorcycle.
- After mounting the rear wheel, keep operating the rear brake until the pressure point returns.
- It is very important to keep the brake disk free from oil and fatty matters, otherwise the braking effects would be strongly reduced.
- Tighten the collar nut with the required torque. A loose wheel spindle may lead to an unstable behavior of your motorcycle.



## Tires, air pressure

Tire type, tire condition, and air pressure level affect the way your motorcycle rides, and they must therefore be checked whenever you are getting ready to go anywhere on your motorcycle. Tire size can be found in the technical specifications. Tire condition has to be checked every time you want to ride your motorcycle. Before leaving, check tires for punctures and nails or other sharp objects that might have become embedded in them.

Tire pressure should be checked regularly on a "cold" tire. Proper pressure (1.0 bar) ensures optimum driving comfort and extends the life of your tires.

### ⚠ WARNING

- Damaged tires must be replaced immediately to protect your youngster.
- Worn tires can have a negative effect on how the motorcycle performs, especially on wet surfaces
- Tire pressure below the normal level will lead to premature tire wear.



## Checking spoke tension

The correct spoke tension is very important for the stability of the wheels and thus for riding safety. A loose spoke causes the wheel to become unbalanced and before long other spokes will have come loose. Check spoke tension, especially on a new motorcycle, at regular intervals. For checking, tap on each spoke with the blade of a screwdriver (see photo). A clear tone must be the result. Dull tones are indicators of loose spokes. If necessary, have the spokes retightened and the wheel centered by a KTM dealer.

### ⚠ WARNING

- Spokes can tear if you continue to ride with them loose. This may lead to an unstable handling of your motorcycle.
- Excessively tensioned spokes may rupture due to local overloading. The spokes must be tensioned to 5 Nm.

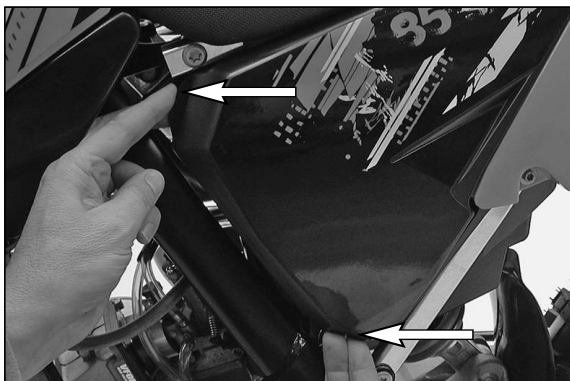

## Cleaning the air filter \*

The air filter must be cleaned prior to each race or whenever dust has accumulated. To clean, lift the filter box cover (see illustration) and pull off towards the front. Detach the filter retainer [1] at the bottom, tilt to the side and remove the air filter [2] and the filter support [3] from the filter box.

### ⚠ WARNING

Do not clean the air filter with fuel or petroleum since these will damage the foam. KTM recommends the products made by Motorex (Bio Dirt Remover and Liquid Bio Power) for air filter maintenance. for cleaning purposes and to oil the air filter.

Thoroughly wash the air filter in special cleaning fluid and allow it to dry well. Only press out the filter, do not wring it out under any circumstances. Oil the dry air filter with a high-grade filter oil. Also clean the air filter box. Check the carburetor collar for damage and that it is filled correctly.

Mount the air filter on the filter support. Mount the filter together with the filter support in the filter box, making sure to center them, and fix them properly with the filter holding bracket.

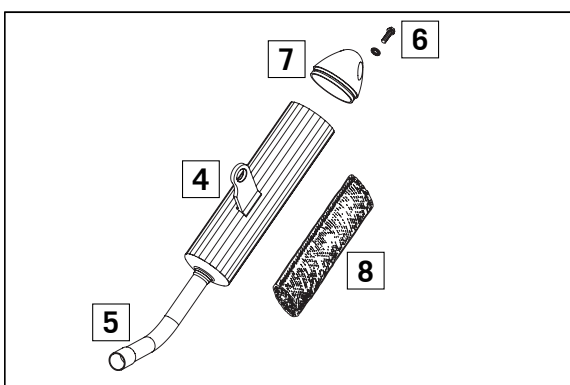
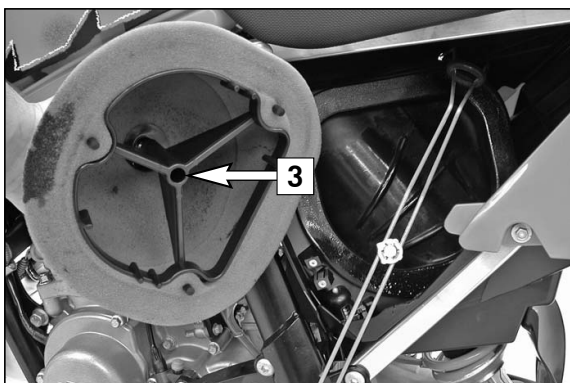
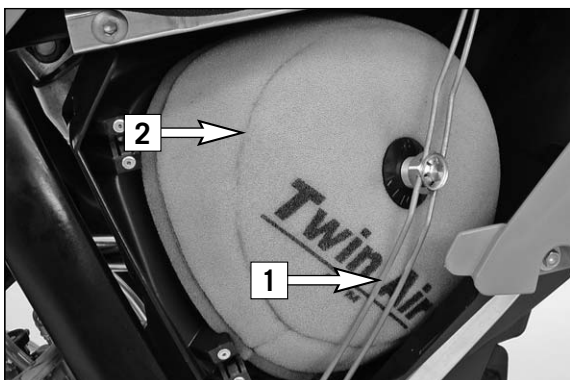

## Exhaust system

The silencer is filled with glass-fiber yarn for damping. When in use, the glass-fiber yarn becomes loose or coked with oil carbon. This can lead to a power loss and a reduction of the silencer damping. The glass-fiber yarn packing can be replaced in a few easy steps.

To replace, remove the silencer from the vehicle and mark the position of the outer tube [4] to the inner tube [5]. Remove screws [6] and the end cap [7]. Pull off the outer tube and remove the old glass-fiber yarn packing [8] from the inner tube. Thoroughly clean all parts.

To assemble, mount a new glass-fiber yarn packing onto the inner tube (see illustration) and slide into the outer tube. Mount end cap and fix with screws [6]. Before tightening the screws, turn the outer tube until they match the positions you marked. Mount the silencer and check the exhaust system for tightness.

Note: Glass fiber yarn packages are offered by your licensed KTM dealer.

### ⚠ WARNING

The exhaust system becomes very hot while the motorcycle is running. To avoid burns do not start work on the exhaust system until it has properly cooled down.



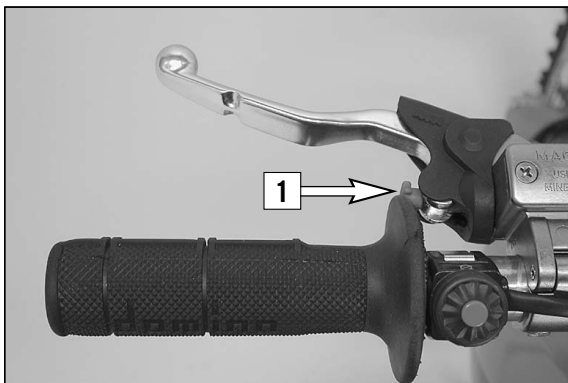

## Changing the original position of the clutch lever

The adjusting screw [1] can be used for individual adjustment of the original position of the clutch lever, thus allowing adjustment to an optimal position for every hand size.

Turning the adjusting screw counterclockwise reduces the distance between the clutch lever and the handlebar. Turning the adjusting screw clockwise increases the distance between the clutch lever and the handlebar.

### ! CAUTION

Adjustment of the clutch lever position is only possible within certain limits. Only turn the adjusting screw manually and never apply excessive force.

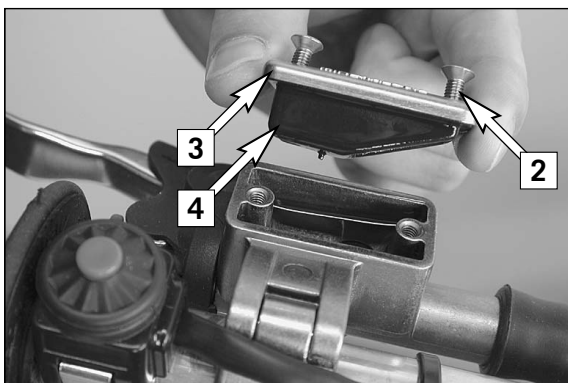

## Checking the oil level of the hydraulic clutch

To check the oil level in the master cylinder of the clutch remove the cover. For this purpose, remove screws [2] and cover [3] together with the rubber boot [4]. The oil level in the horizontal-standing master cylinder should be 4 mm below the upper edge.

If necessary, add SAE 10 biodegradable hydraulic oil (Motorex clutch fluid 75), available from your authorized KTM workshop.

### ! CAUTION

KTM uses biodegradable hydraulic oil for the hydraulic clutch control. Never mix biodegradable hydraulic oils with mineral oils. Never refill with mineral hydraulic oil or brake fluid.

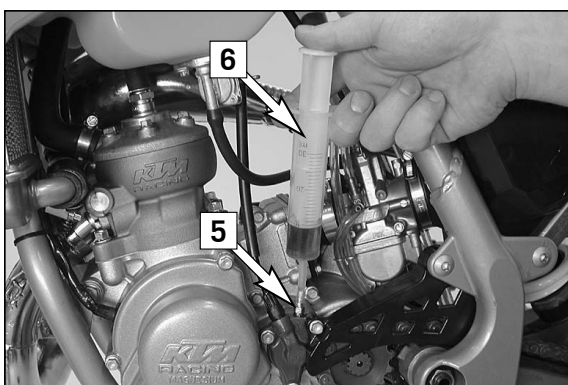

## Bleeding of the hydraulic clutch

To bleed, the cover of the master cylinder of the clutch needs to be removed. For this purpose, remove screws [2] and take off the cover [3] together with the rubber bellows [4]. At the slave cylinder of the clutch, remove the bleeder nipple [5]. In its place, mount the bleeder syringe [6] which is filled with SAE 10 hydraulic oil. Refill oil, until oil is discharged from the bore [7] of the master cylinder in a bubble-free state. Make sure that the oil does not overflow. The bleeder syringe can be purchased from your KTM dealer. Having completed the bleeding procedure, you have to verify that the oil level in the master cylinder is correct. If necessary, fill up with biodegradable hydraulic oil SAE 10 (e.g. Motorex Clutchfluid 75). Biodegradable hydraulic oil is available from your KTM dealer (50ml).

### ! CAUTION

KTM uses biodegradable hydraulic oil for the hydraulic clutch control. Never mix biodegradable hydraulic oils with mineral oils.

Always use biodegradable hydraulic oil SAE 10 (e.g. Motorex Clutchfluid 75) to fill up the master cylinder. Never refill with mineral hydraulic oil or brake fluid.

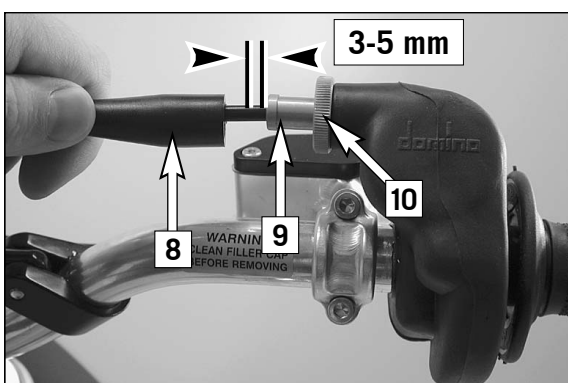
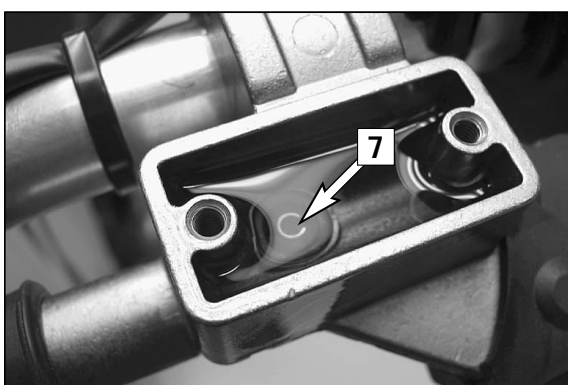

## Adjusting the throttle cable\*

There must always be a 3-5 mm (0.1-0.2 in) play in the throttle cable. To check this, move back the protective cover [8] on the throttle grip. You must be able to lift the outer covering of the cable 3-5 mm from the adjusting screw [9] until resistance is felt.

To adjust, loosen the conical counter nut [10] and turn the adjusting screw accordingly. Finally tighten the conical counter nut and slide the protective cover back on.

To check the correctness of this setting, start the engine, turn the handlebar left and right, in both cases as far as it will go. This must not cause any changes in idling speed. Otherwise, you will have to increase the backlash of the throttle cable.

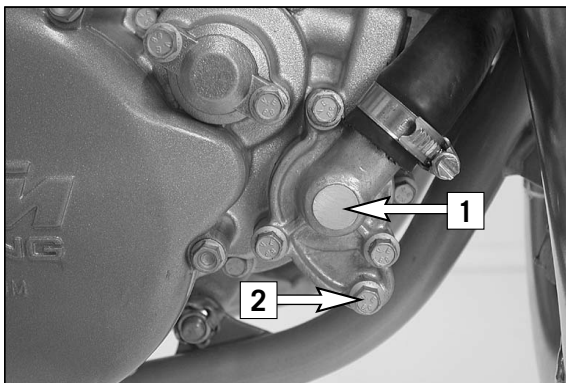

## Cooling system

The water pump [1] in the engine keeps the cooling liquid in circulation. The cooling liquid is cooled by the air stream. Therefore, the cooling effect is reduced when the traveling speed is reduced. Dirty radiators additionally reduce the cooling effect.

The cooling liquid can be drained by removing the screw [2] on the water-pump cover.

### ⚠ WARNING

- If possible, always check level of cooling liquid when the engine is cold. If you have to open the radiator cap [3] when the engine is hot, use a rag to cover the cap and open slowly to release pressure. Caution - scalding hazard.
- Do not detach any radiator hoses while the engine is hot. The escaping hot coolant and the steam may cause serious burns.
- In case you get burnt, hold the affected part of your body under running cold water right away.
- Coolant is toxic. Keep the coolant out of the reach of children.
- In case coolant is ingested, consult a doctor immediately.
- If coolant gets into your eyes, rinse them out with water immediately and consult doctor.

A mixture of 50% antifreeze liquid and 50% water is used as coolant. However, the antifreeze protection must be at least -25° C (-13° F). This mixture offers antifreeze protection but also good corrosion protection and should therefore not be replaced by pure water.

### ! CAUTION

For the cooling system, use only with high-grade antifreeze (Motorex Anti-Freeze). Using lower-grade antifreeze agents can cause corrosion and coolant foaming.

Pressure induced by heating of the coolant in the system is controlled by a valve in the radiator cap [3]; a water temperature rising up to 120° C (248° F) is admissible, without fear of problems.

## Checking coolant level

The coolant should be 10 mm (0.4 in) above the radiator fins when the engine is cold (see illustr.). In the event of the coolant being drained, always fill and bleed the system.

### ⚠ WARNING

If possible, always check the level of cooling liquid when the engine is cold. If you have to open the radiator cap when the engine is hot, use a rag to cover the cap and open slowly to release pressure.

### ! CAUTION

The cooling system must be bled after draining the cooling liquid or after adding more than 0.25 l (0.06 US gallons) cooling liquid.

## Refilling/Bleeding the cooling system

The cooling system must be bled as described below after draining the cooling liquid or after adding more than 0.25 l (0.06 US gallons) cooling liquid.

Make sure that the drain screw [4] is fastened.

Pour approx. 0.5 litres (0.13 US gallons) coolant into the system.

Remove the screw [5] on the right radiator.

Now add cooling liquid until it emerges free of bubbles at the right radiator. Then immediately mount the screw so that no more air can enter the right radiator.

Top up the left radiator until the coolant can be seen approx. 10 mm (0.4 in) above the radiator fins.

Check the coolant level again after a short ride.

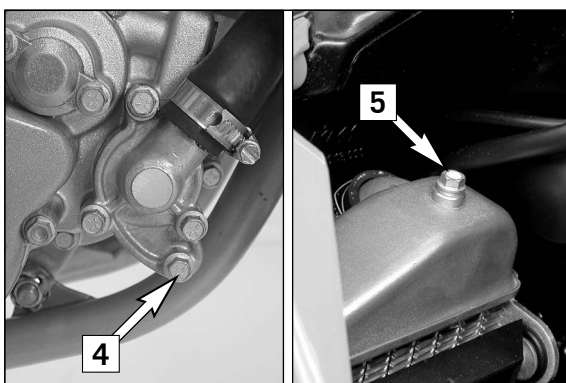
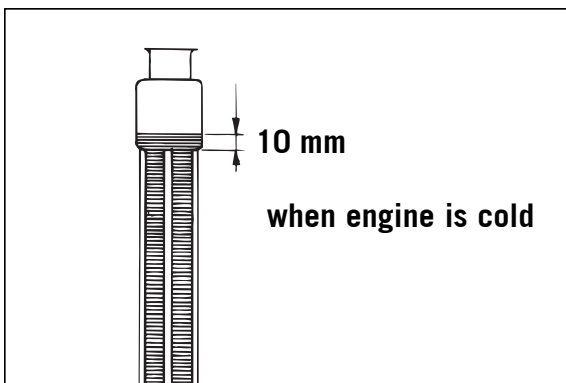
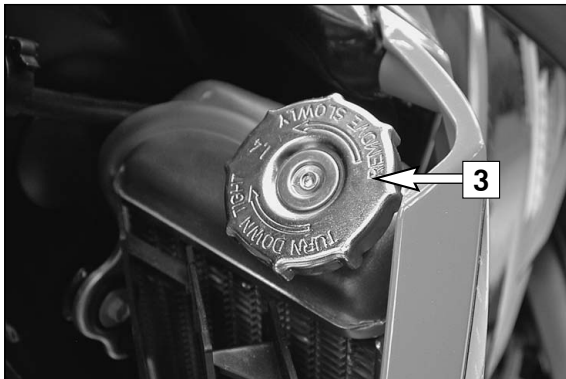

# MAINTENANCE WORK ON CHASSIS AND ENGINE »

## Carburetor adjustment \*

Basic information on the original carburetor setting

The original carburetor setting was adapted for an altitude of approx. 500 meters (1600 ft.) above sea level, and the ambient temperature of approx. 20° C (68° F), mainly for off-road use and central European premium-grade fuel (ROZ 95).

Mixing ratio 2-stroke motor oil : super fuel 1:40 - 1:60 .

Basic information of changing the carburetor setting

Always start out from the original carburetor setting. Essential requirements are a clean air filter system, air-tight exhaust system and an intact carburetor. Experience has shown that adjusting the main jet, the idling jet and the jet needle is sufficient and that changes to other parts of the carburetor will not greatly affect engine performance.

RULE OF THUMB: high altitude or high temperatures → choose leaner carburetor adjustment  
low altitude or low temperatures → choose richer carburetor adjustment

### ⚠ WARNING

- Only use unleaded fuel with at least RON 95 (USA = Premium RON 91), mixed with high grade two-stroke oil. Other types of gasoline can cause engine failure, and their use will void your warranty.
- Only use high-grade 2-stroke engine oil of known brands (e. g. Motorex Cross Power 2T).
- Do not use premixed two-stroke oils, oils for outboard engines or normal engine oil to prepare the mixture.
- Not enough oil or low-grade oil can cause erosion of the piston. If you use too much oil, the engine can start smoking and foul the spark plug.
- In the case of a leaner adjustment of the carburetor proceed cautiously. Always reduce the jet size in steps of one number to avoid overheating and piston seizure.

NOTE: If the engine does not run properly, despite a changed adjustment look for mechanical faults and check the ignition system.

Basic information on carburetor wear:

Engine vibrations subject the throttle slide, jet needle, float needle valve and the main nozzle holder to extreme wear. Wear leads to malfunctioning of the carburetor (e.g. over-enrichment). These parts should be inspected and/or replaced after 100 operating hours.

## Idling range A

Operation with closed throttle valve. This range is influenced by the position of the air control screw [1] and the air control screw [2]. Only make adjustments when the engine is hot.

To this end, slightly increase the idling speed of the engine by means of the air control screw. Turning it clockwise produces a higher idling speed and turning the screw counterclockwise produces a lower idling speed. Create a round and stable engine speed using the air control screw (basic position of the air control screw = open by 1.5 turns). Then adjust to the normal idling speed by means of the air control screw.

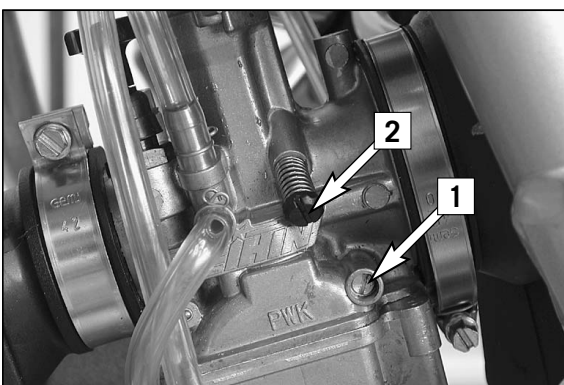

## Opening up – B

Engine behavior when the throttle opens. The idle jet and the shape of the throttle valve influences this range. If, despite good idling-speed and part-throttle setting, the engine sputters and smokes when the throttle is fully opened and develops its full power not smoothly but suddenly at high engine speeds, the mixture to the carburetor will be too rich, the fuel level too high or the float needle is leaking.

## Part-throttle range – C

Operation with partly open throttle valve. This range is only influenced by the jet needle (shape and position). The optimum part-throttle setting is controlled by the idling setting in the lower range and by the main jet in the upper range. If the engine runs on a four-stroke cycle or with reduced power when it is accelerated with the throttle partly open, the jet needle must be lowered by one notch. If the engine pings, especially when accelerating under full power at maximum engine revs, the jet needle should be raised.

If these faults should occur at the lower end of the part throttle range at a four-stroke running, make the idling range leaner; if the engine pings, adjust the idling range richer.

## Full throttle range – D

Operation with the throttle fully open (flat out). This range is influenced by the main jet and the jet needle. If the porcelain of the new spark plug is found to have a very bright or white coating or if the engine rings, after a short distance of riding flat out, a larger main jet is required. If the porcelain is dark brown or black with soot the main jet must be replaced by a smaller one.

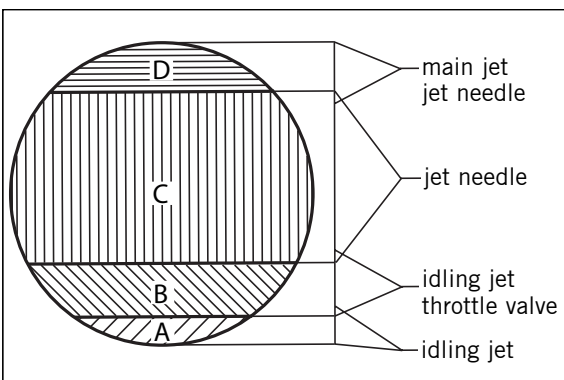

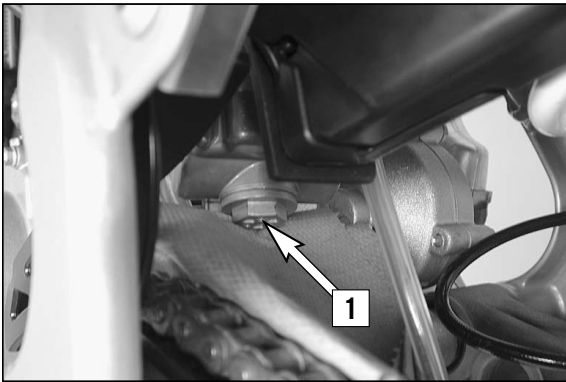

## Draining the float chamber of the carburetor

Following every wet-cleaning procedure, the float chamber of the carburetor should be drained in order to remove any water that may have penetrated into it. Water in the float chamber leads to engine malfunction. Make sure you do this while the engine is cold. Close the fuel tap and place a cloth under the carburetor which is capable of absorbing the leaking fuel. Unscrew the plug [1] and clean it with compressed air. Then, mount the plug together with the gasket and tighten to 4 Nm, open fuel tap, and check the float chamber for leaks.

### ⚠ WARNING

Fuel is easily flammable and toxic. When handling fuel, be sure to exercise the utmost caution. Never perform any work on the fuel system near of open flames or burning cigarettes. Always allow the engine to cool off first. Immediately clean up any fuel which may have been spilled. Materials saturated with fuel are also easily flammable. In case you ingested fuel or fuel splashed into your eyes, consult a doctor immediately. Dispose of the fuel properly!

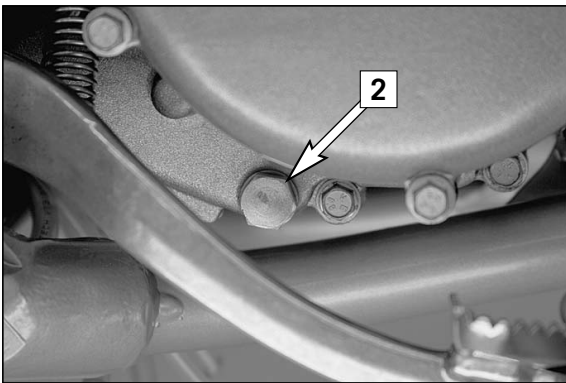

## Checking gear oil level

To check the gear oil, warm up the engine to operating temperature with a low load and place the motorcycle on an even surface. Remove the oil drain plug [2] and allow the gear oil to drain into a vessel. Clean the sealing area, mount the oil drain plug and gasket and tighten to 15 Nm. Remove the oil filler screw [4] and add 0.5 liters of gear oil (e.g. Motorex Topspeed 4T 15W50). Mount the oil filler screw and check the engine for leaks.

If the gear oil is still clean you can continue to use it up to your next service.

### ! CAUTION

- too little oil or a poor oil quality will cause the transmission to wear prematurely. Only use brand-name oils.
- due to a change in the fluid capacities the inspection screw [3] can no longer be used.

### ⚠ WARNING

Engines and engine oil are extremely hot at operating temperatures - be careful not to burn yourself.

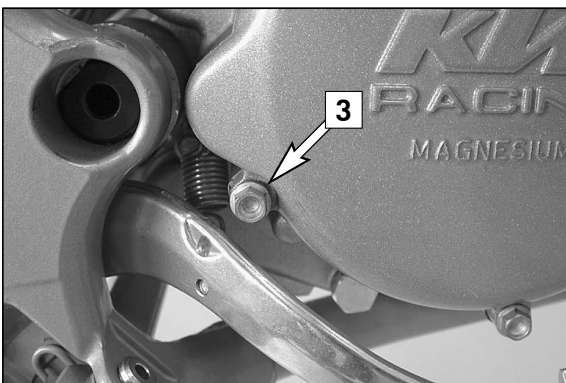

## Changing gear oil \*

Before changing the gear oil warm up the engine and park the motorcycle on a horizontal surface. Remove the oil drain plug [2] and drain the used oil into an appropriate container. Clean the sealing surface. Mount the oil drain plug together with its gasket and tighten to 15 Nm.

Remove the filler plug [4] and add 0.5 l gear oil (e.g. Motorex Topspeed 4T 15W50). Mount the filler plug and check the engine for leaks.

### ! CAUTION

- too little oil or a poor oil quality will cause the transmission to wear prematurely. Only use brand-name oils.
- due to a change in the fluid capacities the inspection screw [3] can no longer be used.

### ⚠ WARNING

Engines and engine oil are extremely hot at operating temperatures - be careful not to burn yourself.

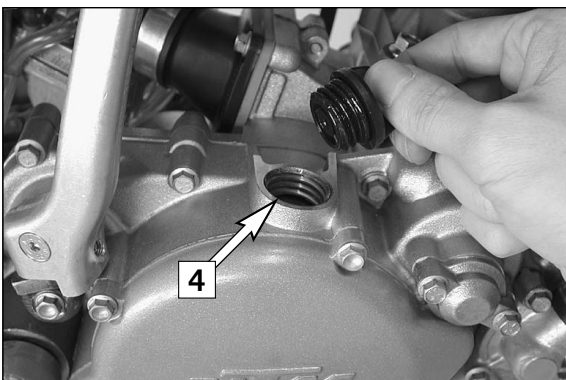

## TROUBLE SHOOTING »

If you let the specified maintenance work on your motorcycle be carried out, disturbances can hardly be expected. Should an error occur nevertheless, we advise you to use the trouble shooting chart in order to find the cause of error. We would like to point out that many operations cannot be performed by oneself. In case of uncertainty, please contact a KTM-dealer.

TROUBLE	CAUSE	REMEDY
Engine fails to start	Operating error	Open fuel tap, replenish fuel, do not use choke
	The motorcycle was not driven for a longer period of time, leaving old fuel in the float chamber	The highly inflammable components in modern fuels volatilize if left standing for longer periods of time. If the motorcycle has not been used for over 1 week, the fuel should be drained from the float chamber. The engine will start up immediately if the float chamber is filled with fresh, ignitable fuel
	Fuel supply interrupted	Close fuel tap, loosen fuel hose at carburettor, lead into a basin and open fuel tap, <ul style="list-style-type: none"> <li>– if fuel leaks out, clean carburettor</li> <li>– if no fuel leaks out, check tank ventilation, i.e. clean fuel tap</li> </ul>
	Electrode distance too great	Reduce electrode distance (0.60 mm)
	Plug fouled by oil, wet or bridged	Clean spark plug or renew
	Ignition wire or spark plug connector damaged	Dismount spark plug, connect ignition cable, hold to ground (blank place on engine) and actuate kickstarter, a strong spark must be produced at the spark plug <ul style="list-style-type: none"> <li>– If no spark is produced, loosen spark plug cap from ignition cable, hold about 5 mm from ground and actuate kickstarter</li> <li>– If a spark now occurs, replace spark plug cap</li> <li>– If no spark is produced, control ignition system</li> </ul>
	Kill button wire or short-circuit switch faulty	Disconnect black coloured cable from short circuit button at ignition coil and check ignition spark. If the spark is O.K. repair defective part of cable or ignition switch
	Loose ignition cable connectors	Inspect cable connectors
	Spark too weak	Examine ignition system
Water in the carburetor and jets blocked	Dismantle and clean carburetor	
Engine without idle running	Idle adjusting screw out of adjustment	Readjust idle running or replace idle adjusting screw
	Ignition system damaged	Examine ignition system
	Wear	Overhaul engine
Engine has not enough power	Charred glass fiber yarn in silencer	Renew filling
	Air filter obstructed	Clean or renew airfilter
	Fuel supply partly interrupted or blocked	Blow through fuel pipe and clean carburetor
	Loss of compression through loose spark plug	Tighten spark plug
	Exhaust system damaged	Check exhaust system for damage
	Engine has not enough preignition	Check and adjust ignition



# TROUBLE SHOOTING »

TROUBLE	CAUSE	REMEDY
Engine has not enough power	Reed paddles tensionless or damaged, surface of reed valve housing damaged  Wear	Replace reed paddles or reed valve housing  Overhaul engine
Engine revs not up and running in four stroke cycle	Carburetor overflows if level adjust too high, float needle seating is dirty or enlarged  Loose carburetor jets	Clean carburetor, if necessary replace float needle and adjust level  Tighten jets
High rpm misfiring	Incorrect heat range spark plug or low quality spark plug  Loose, corroded or non conductive ignition socket connector	Refer to technical data section  Check and seal with silicon
Engine splutters into the carburetor	Lack of fuel  Spark plug with incorrect heat value (Ignition by incandescence)  Engine takes air out of control	Clean fuel pipes, examine tank aeration and clean  Fit correct spark plug  Check intake flange and carburetor if firmly setted
Engine overheating	Insufficient liquid in cooling system  Radiator fins clogged  Frothing in cooling system  Pinched or kinked water hoses  Incorrect ignition timing because of loose stator screws  Incorrect compression ratio	Top up coolant and bleed cooling system check cooling system for leaks  Clean radiator fins with water jet  Renew coolant using branded anti-freeze/anti-corrosive (Motorex Anti-Freeze)  Replace with correct routed hoses  Readjust to correct ignition timing specifications, secure screws with Loctite 243  Measure and adjust compression ratio
Emission of white smoke (steam)	Cylinder head or O-ring of cylinder head gasket leaks	Check cylinder head, replace O-ring
Excessive oil escapes from transmission breather tube	Excessive oil quantity in transmission	Correct transmission oil level
Water in transmission oil	Shaft seal ring of the water pump defect	Replace shaft seal ring of the water pump.

## CLEANING »

Clean your motorcycle regularly in order to keep its painted finish looking shiny and new. The best manner would be to use warm water that has been mixed with a commercially available washing detergent and a sponge. The hard dirt can be removed before with the help of a soft water jet.

### ! CAUTION

**Never clean your motorcycle with a high-pressured cleaner or a high-pressured water jet. otherwise the water might run into the electrical components, connectors, sheathed cables, bearings, carburetor etc. and cause malfunctions, i.e., lead to the premature destruction of these parts.**

- You should use commercially available detergents to clean the motorcycle. Heavily soiled parts should also be cleaned with the help of a paint brush.
- Before cleaning with water, plug the exhaust pipe to prevent water ingress.
- After the motorcycle has been rinsed with a soft water jet, it should be dried by air pressure and a cloth. Then take a short drive until the engine has reached its operating temperature, and also operate the brakes. The heat also causes the water at the inaccessible parts of the engine and the brakes to evaporate.
- Slide back the protective covers on the handlebar-mounted instruments so that any water that may have seeped into this part of the motorcycle is allowed to evaporate.
- After the motorcycle has cooled down, oil and grease all the gliding bearing parts. Also treat the chain with a chain spray.
- To prevent failures in the electric system, you should treat the short circuit button with a contact spray.

## STORAGE »

If you want to put your motorcycle away for longer periods of time, please observe the following instructions:

- Clean motorcycle thoroughly (see chapter: CLEANING)
- Change engine oil (old engine oil contains aggressive contaminations).
- Check antifreeze and amount of cooling liquid.
- Let the engine warm up again, close fuel tap and wait until the engine dies off by itself. In this way, the carburetor jets are prevented from becoming resin-clogged by the old fuel.
- Remove spark plug and fill in approx. 5 ccm of engine oil into the cylinder through the opening. Actuate kickstarter 10 times in order to distribute the oil onto the cylinder walls and mount the spark plug.
- Let fuel flow out of tank into an appropriate basin.
- Correct tire pressure.
- Lubricate bearing points of the control levers, footrests, etc. as well as the chain.
- The storage place should be dry and not be subjected to overly great temperature fluctuations.
- Cover the motorcycle with an air permeable tarpaulin or blanket. Do not use airtight materials, as possible humidity might not be able to escape and thereby cause corrosion.

### ⚠ WARNING

**It would be very bad to let the engine run for a short time during the storage period. The engine would not get warmed up enough and the thus developed steam would condense during the combustion process and cause the exhaust to rust.**

### Use after period of storage

- Fill up tank with fresh fuel.
- Check motorcycle as before each start (see driving instructions).
- Take a short, careful test ride first.

NOTE: Before you put your motorcycle away for the winter, you should check all parts for their function and wear. Should any service jobs, repairs, or any refitting be necessary, you should have them carried out during the off-season (lower workload at mechanics' shops). This way, you can avoid the long waiting times at your shop at the beginning of the next biking season.

# TECHNICAL SPECIFICATIONS – CHASSIS »

CHASSIS	85 SX/XC (17"/14")	85 SX 105 SX/XC (19"/16")
Frame	Central chrome-moly-steel frame	
Fork	telescopic fork WP Suspension 4357 MXMA	
Wheel travel front/rear	275 mm / 300 mm (10.82/11.81 in)	
Rear suspension	WP PDS 4618 (Progressive Damping System) shock absorber	
Front brake	Disc brake Ø 220 mm (8.66 in), 4 piston	
Rear brake	Disc brake Ø 200 mm (7.87 in), 4 piston	
Tires front	70/100-17" Pirelli NHS 40 M	70/100-19" Pirelli NHS 42M
Tires rear	90/100-14" Pirelli NHS 49	90/100-16" Pirelli NHS 51
Air pressure	1.0 bar	
Fuel tank capacity	5.1 liter	
Final drive ratio	14 : 46 t	14 : 49 t
Chain	1/2 x 5/16" 122 rolls (SX)	1/2 x 5/16" O-Ring 122 rolls (XC)
Steering angle	66 °	
Wheel base	1290 mm	
Seat height, unloaded	865 mm	900 mm
Ground clearance	385 mm	415 mm
Dead weight without fuel	66 kg	68 kg
Rider's body weight	max. 75 kg	
Recommended age of rider	10 to 15 years	
Engine	CR-85/CR-105	

## STANDARD ADJUSTMENT – FORK (SX)

	WP 4357 MXMA 05187E05
Compression adjuster	15
Rebound adjuster	20
Spring	3,4 N/mm
Air chamber length	110 mm
Fork oil	SAE 5

## STANDARD ADJUSTMENT – FORK (XC)

	WP 4357 MXMA 05187E06
Compression adjuster	20
Rebound adjuster	20
Spring	3,4 N/mm
Air chamber length	110 mm
Fork oil	SAE 5

## STANDARD ADJUSTMENT – SHOCK ABSORBER (SX)

	WP 4618 PDS-DCC WP 15187E02
Compression adjuster	15 LS (LOW SPEED) 2 HS (HIGH SPEED)
Rebound adjuster	22
Spring	35-215
Spring preload	7 MM

## STANDARD ADJUSTMENT – SHOCK ABSORBER (XC)

	WP 4618 PDS-DCC WP 15187E04
Compression adjuster	15 LS (LOW SPEED) 2 HS (HIGH SPEED)
Rebound adjuster	22
Spring	35-215
Spring preload	7 MM

## TECHNICAL SPECIFICATIONS - CHASSIS »

TIGHTENING TORQUES - CHASSIS		
Hexagon bolt - brake caliper front	M 8	Loctite 243 + 25 Nm
Allan head screw - brake pads rear	M6	5 Nm
Flat head bolt - brake discs	M6	14 Nm
Hexagon nut - front wheel spindle	M10x1.5	40 Nm
Hexagon nut - rear wheel spindle	M20x1.5	80 Nm
Hexagon nut - swingarm bolt	M14x1.5	75 Nm
Clamping bolts - top triple clamp	M8	25 Nm
Clamping bolts - bottom triple clamp	M8	15 Nm
Bolt - handlebar clamp	M8	20 Nm
Spoke nipple	M4,5	5 Nm
Other chassis bolts	M6	10 Nm
	M8	25 Nm
	M10	45 Nm

# TECHNICAL SPECIFICATIONS - ENGINE »

ENGINE	85 SX/XC	105 SX/XC
Design	Liquid cooled single cylinder two-stroke engine with reed valve intake	
Displacement	84.93 ccm	103.96 ccm
Bore/stroke	47 / 48.95 mm	52 / 48.95 mm
Fuel	unleaded fuel with at least RON 95 (USA = Premium RON 91), mixed with high grade two-stroke oil	
Oil/gasoline ratio	1 : 40 - 1 : 60 when using high grade two-stroke oil (e.g. Motorex 2T Crosspower), when in doubt, please contact your importer	
Lubrication	mixture lubrication	
Crankshaft bearing	deep-groove ball bearing, cylinder roller bearing	
Connecting rod bearing	needle bearing	
Piston pin bearing	needle bearing	
Piston rings	1 compression ring	
Primary drive	straight cut spur gears, 19 : 66 t	
Clutch	multiple disc clutch in oil bath, hydraulic operated (Motorex Kupplungs-Fluid 75)	
Transmission	6 speed, claw actuated	
Gear ratio	1 <sup>st</sup> gear 11 : 29 2 <sup>nd</sup> gear 14 : 28 3 <sup>rd</sup> gear 16 : 26 4 <sup>th</sup> gear 19 : 26 5 <sup>th</sup> gear 21 : 25 6 <sup>th</sup> gear 20 : 21	
Transmission oil	0.5 liter engine oil Motorex Topspeed 4T 15W50	
Ignition system	Moric Digital 2M1	
Spark plug	NGK BR 9 ECMVX	
Electrode gap	0.60 mm	
Carburetor	flat-slide carburetor, carburetor see table	
Coolant	1 liter, mixture 50% antifreeze, 50% distilled water, at least -25° C (-13° F)	
Air filter	wet foam type air filter insert	

BASIC CARBURETOR SETTING	
Carburetor	Keihin PWK 28
Main jet	118
Needle jet	2.6
Idling jet	45
Jet needle	N5HG
Needle position from top	III
Throttle valve	3.5
Starting jet	62
Air adjustment screw open	1,5

TIGHTENING TORQUES - ENGINE		
Flange bolts - cylinder-head	M 6	10 Nm
Nuts-cylinder base	M 8	30 Nm
Flywheel collar nut	M 12X1	60 Nm
Primary gear bolt	M 10X1,25	Loctite 243 + 80 Nm
Nut for inner clutch hub	M 14X1,25	Loctite 243 + 60 Nm
Crankcase and cover bolts	M 6	8 Nm
Spark plug	M 14X1,25	20 Nm
Reed valve housing	M 14X1,5	75 Nm
Kickstarter	M 6	6 Nm
Shift lever	M 6	Loctite 243 + 12 Nm
Swingarm pivot	M 6	Loctite 243 + 12 Nm
Other bolts	M 5	6 Nm
	M 6	10 Nm

# CARBURETOR SETTING »

VERGASERREGULIERUNG CARBURETOR SETTING KEIHIN PWK 28		85/105 SX/XC 2009					
MEERESHÖHE ALTITUDE ↓	TEMPERATUR TEMPERATURE →	- 20°C bis -7°C -2°F to 20°F	- 6°C bis 5°C 19°F to 41°F	6°C bis 15°C 42°F to 60°F	16°C bis 24°C 61°F to 78°F	25°C bis 38°C 79°F to 98°F	
3000 m 10000 ft ↑ 2301 m 7501 ft	LSO ASO LD IJ NADEL NEEDLE POS POS HD MJ	1,5 45 N5HG 2 118	1,75 42 N5HH 3 115	2 40 N5HH 2 115	2,25 38 N5HH 1 115	2,5 38 N5HH 1 115	
2300 m 7500 ft ↑ 1501 m 5001 ft	LSO ASO LD IJ NADEL NEEDLE POS POS HD MJ	1,25 48 N5HG 3 120	1,5 45 N5HG 2 118	1,75 42 N5HH 3 115	2 40 N5HH 2 115	2,25 38 N5HH 1 115	
1500 m 5000 ft ↑ 751 m 2501 ft	LSO ASO LD IJ NADEL NEEDLE POS POS HD MJ	1 50 N5HF 3 122	1,25 48 N5HG 3 120	1,5 45 N5HG 2 118	1,75 42 N5HH 2 115	2 40 N5HH 2 115	
750 m 2500 ft ↑ 301 m 1001 ft	LSO ASO LD IJ NADEL NEEDLE POS POS HD MJ	0,75 50 N5HF 4 125	1 50 N5HF 3 122	1,25 48 N5HG 3 120	<b>1,5</b> <b>45</b> <b>N5HG</b> <b>3</b> <b>118</b>	1,75 42 N5HH 2 115	
300 m 1000 ft ↑ Meeresniveau Sea level	LSO ASO LD IJ NADEL NEEDLE POS POS HD MJ	0,5 50 N5HF 5 125	0,75 50 N5HF 4 125	1 50 N5HG 3 122	1,25 48 N5HG 3 120	1,5 45 N5HG 2 118	

ENGLISH

37

LSO = Luftregulierschraube offen  
LD = Leerlaufdüse  
POS = Nadel Clip Position von oben  
HD = Hauptdüse

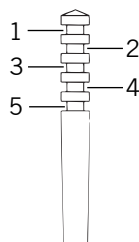

ASO = Air screw open from fully-seated  
IJ = Idling jet  
POS = Needle clip position from top  
MJ = Main jet

**NICHT FÜR STRASSEN BETRIEB  
UND SANDSTRECKEN**

**NOT FOR HIGHWAY USE  
AND SAND TRACKS**

Kraftstoff: Super Bleifrei ROZ 95

Fuel: unleaded fuel with at least RON 95  
USA = Premium PON 91

	Page		Page
Adjusting free travel of the hand brake lever . . . . .	21	Filler cap . . . . .	7
Adjusting the throttle cable . . . . .	27	Foot brake pedal . . . . .	8
Basic suspension setup for the weight of the driver . . .	18	Fuel tap . . . . .	7
Bleeding of the hydraulic clutch . . . . .	27	General information about KTM disc brakes . . . . .	21
Braking . . . . .	13	General tips and warnings for starting the motorcycle .	10
Breather plug front fork . . . . .	16	Hand brake lever . . . . .	6
Carburetor adjustment . . . . .	29	How to change the handlebar position . . . . .	17
Carburetor setting . . . . .	37	Important information for parents about safe driving . .	4
Chain maintenance . . . . .	20	Instructions for the first ride . . . . .	10
Changing basic position of the brake pedal . . . . .	23	Kickstarter . . . . .	8
Changing gear oil . . . . .	30	Maintenance work on chassis and engine . . . . .	16
Changing the original position of the clutch lever . . .	27	Operation instruments . . . . .	6
Changing the spring preloading of the shock absorber .	17	Overview of the shock absorber springs . . . . .	19
Chassis number . . . . .	6	Overview of the telescopic fork springs . . . . .	19
Checking and adjusting the steering head bearing . . .	16	Periodic maintenance schedule . . . . .	14
Checking chain tension . . . . .	20	Plugin- Stand . . . . .	8
Checking coolant level . . . . .	28	Rebound damping function of the shock absorber . . . .	9
Checking front brake pads . . . . .	22	Rebound damping of fork . . . . .	8
Checking gear oil level . . . . .	30	Refilling the rear brake fluid reservoir . . . . .	23
Checking rear brake pads . . . . .	23	Refilling/Bleeding the cooling system . . . . .	28
Checking spoke tension . . . . .	25	Refueling, fuel . . . . .	13
Checking the basic setup of the telescopic fork . . . .	19	Replacing the front brake pads . . . . .	22
Checking the brake fluid level/ refilling . . . . .	22	Running in . . . . .	10
Checking the oil level of the hydraulic clutch . . . . .	27	Serial number locations . . . . .	6
Checking the rear brake fluid level . . . . .	23	Shift lever . . . . .	7
Checking the shock absorber and spring . . . . .	18	Shifting/Riding . . . . .	12
Choke . . . . .	7	Short circuit button . . . . .	7
Cleaning . . . . .	33	Side stand . . . . .	8
Cleaning the air filter . . . . .	26	Standard high-speed setting: . . . . .	9
Cleaning the dust sleeves of the telescopic fork . . . .	17	Standard low-speed setting: . . . . .	9
Clutch lever . . . . .	6	Starting off . . . . .	12
Compression damping of fork . . . . .	8	Starting when the engine is cold . . . . .	12
Cooling system . . . . .	28	Starting when the engine is warm . . . . .	12
Correct chain tension . . . . .	20	Stopping . . . . .	13
Damping action during compression of shock absorber .	9	Storage . . . . .	33
Determining the riding sag of the shock absorber . . .	18	Technical Specifications – Chassis . . . . .	34
Determining the static sag of the shock absorber . . .	18	Technical specifications - engine . . . . .	36
Dismounting and mounting the front wheel . . . . .	24	Tires, air pressure . . . . .	25
Dismounting and mounting the rear wheel . . . . .	25	Trouble shooting . . . . .	31
Draining the float chamber of the carburetor . . . . .	30	Use after period of storage . . . . .	33
Driving instructions . . . . .	11	What to do when the engine is “flooded“ . . . . .	12
Engine number . . . . .	6	What you should check before each start . . . . .	11
Exhaust system . . . . .	26		









3211346en



KTM Group Partner

4/2008 FOTO: MITTERBAUER



KTM-Sportmotorcycle AG  
A-5230 Mattighofen  
[www.ktm.com](http://www.ktm.com)